

OLYMPUS®

INSTRUCTIONS

(and Reprocessing)

OES BRONCHOFIBERSCOPE

OLYMPUS BF TYPE 40

OLYMPUS BF TYPE P40

OLYMPUS BF TYPE 1T40

OLYMPUS BF TYPE XT40

OLYMPUS BF TYPE 3C40

OLYMPUS BF TYPE XP40

USA: CAUTION: Federal law restricts this device to sale by or on the order of a physician.

Contents

Symbols

Important Information-Please Read Before Use

Intended Use	2
Instruction Manual	2
User Qualifications	2
Instrument Compatibility	2
Reprocessing and Storage	3
Repair and Modification	3
Signal Words	3
Warnings and Cautions	4

Chapter 1 Checking the Package Contents

1.1 Checking the Package Contents	6
---	---

Chapter 2 Instrument Nomenclature and Specifications

2.1 Nomenclature	8
2.2 Endoscope Functions	10
2.3 Specifications	11

Chapter 3 Preparation and Inspection

3.1 Preparation of the Equipment	15
3.2 Preparation and Inspection of the Endoscope	16
3.3 Preparation and Inspection of Accessories	18
3.4 Attaching Accessories to the Endoscope	19
3.5 Preparation, Inspection and Connection of the Ancillary Equipment	21
3.6 Inspection of the Endoscopic System	21

Chapter 4 Operation

4.1 Insertion	24
4.2 Using Endo-Therapy Accessories	28
4.3 Withdrawal of the Endoscope	33
4.4 Transportation of the Endoscope	34

Chapter 5 Reprocessing: General Policy

5.1 Instructions	35
5.2 Precautions	36

Chapter 6 Compatible Reprocessing Methods and Chemical Agents	
6.1	Compatibility Summary 37
6.2	Detergent Solution 38
6.3	Disinfectant Solution 38
6.4	Rinsing Water 39
6.5	ETO Gas Sterilization 39
6.6	Steam Sterilization (Autoclaving) of Accessories 41
Chapter 7 Cleaning, Disinfection and Sterilization Procedures	
7.1	Required Reprocessing Equipment 42
7.2	Cleaning, Disinfection and Sterilization Procedures 46
7.3	Precleaning 47
7.4	Leakage Testing 49
7.5	Manual Cleaning 51
7.6	High Level Disinfection 57
7.7	Rinsing After High Level Disinfection 59
7.8	Sterilization 61
7.9	Cleaning, Disinfection and Sterilization Procedures for Reusable Parts and Cleaning Equipment 62
Chapter 8 Washing and Disinfection Equipment	
8.1	Washing and Disinfection Equipment 66
Chapter 9 Storage	
9.1	Storage 67
Chapter 10 Troubleshooting	
10.1	Troubleshooting Guide 68
10.2	Returning the Endoscope for Repair 70
Appendix	
	System Chart 71

Symbols

The meaning(s) of the symbol(s) shown on the package and/or this instrument are as follows:



Refer to instructions.



Do not reuse.



Lot number.



Type BF applied part



Endoscope

Important Information-Please Read Before Use

Intended Use

These instruments have been designed to be used with an Olympus Light Source, documentation equipment, display monitor, Endo-Therapy Accessories and other ancillary equipment for endoscopic diagnosis and treatment within the airways and tracheobronchial tree.

Do not use these instruments for any purpose other than their intended use.

Instruction Manual

This instruction manual contains essential information on using these instruments safely and effectively. Before use, thoroughly review this manual and the manuals of all equipment which will be used during the procedure and use these instruments as instructed.

Keep this and all related instruction manuals in a safe, accessible location.

If you have any questions or comments about any information in this manual, please contact Olympus.

User Qualifications

The operator of these instruments must be a physician or medical personnel under the supervision of a physician and must have received sufficient training in clinical endoscopic technique. This manual, therefore, does not explain or discuss clinical endoscopic procedures.

Instrument Compatibility

Refer to the "System Chart" in the Appendix to confirm that this instrument is compatible with the ancillary equipment being used. Using incompatible equipment can result in patient injury or equipment damage.

Reprocessing and Storage

This instrument was not disinfected or sterilized before shipment. Before using this instrument for the first time, reprocess it according to the instructions in Chapter 7, "Cleaning, Disinfection and Sterilization Procedures".

After using this instrument, reprocess and store it according to the instructions in Chapters 5 through 9. Improper and/or incomplete reprocessing or storage can present an infection control risk, cause equipment damage or reduce performance.

Repair and Modification

This instrument does not contain any user-serviceable parts. Do not disassemble, modify or attempt to repair it; patient or user injury and/or equipment damage can result.

Some problems that appear to be malfunctions may be correctable by referring to Chapter 10, "Troubleshooting". If the problem cannot be resolved using the information in Chapter 10, contact Olympus.

Signal Words

The following signal words are used throughout this manual:

- | | |
|----------------|---|
| WARNING | Indicates a potentially hazardous situation which, if not avoided, could result in death or serious injury. |
| CAUTION | Indicates a potentially hazardous situation which, if not avoided, may result in minor or moderate injury. It may also be used to alert against unsafe practices or potential equipment damage. |
| NOTE | Indicates additional helpful information. |

Warnings and Cautions

Follow the warnings and cautions described below when handling this instrument. This information is supplemented by the warnings and cautions described in each chapter.

- WARNING**
- S Never perform electrosurgery with BF-3C40/XP40, because the Distal End of this instrument is not insulated. Patient injury can result.
 - S Never perform angulation control, suction control or insertion/withdrawal of the endoscope's Insertion Tube without viewing the endoscopic image. Patient injury can result.
 - S Do not touch the Light Guide immediately after removing it from the Light Source because it is extremely hot.

- CAUTION**
- S Do not pull the Universal Cord. The Endoscope Connector will be pulled out from the output socket of the Light Source and the endoscopic image will not be visible.
 - S Do not coil the Insertion Tube and Universal Cord with a diameter of less than 10 cm. Equipment damage can result.
 - S Do not hit to the Distal End of the Insertion Tube or allow it to strike other objects. The objective lens surface of the Distal End is particularly fragile, and vision abnormalities may result.
 - S Do not twist or bend the Bending Section by hands. Equipment damage may result.
 - S Do not squeeze the Bending Section forcefully. The covering of the Bending Section may stretch or break and cause water leaks.
 - S Do not hit or bend the Electrical Contacts on the Endoscope Connector. The connection to the Light Source may be impaired and faulty contact can result.
 - S Do not scratch the Electrical Contacts of the Eyepiece Section with tweezers or other sharp instruments. Faulty contact with the camera equipment can result.

Details on clinical endoscopic technique are the responsibility of trained specialists. Patient safety in endoscopic examinations and endoscopic treatment can be ensured through appropriate handling by the physician and the medical facility. Examples of inappropriate handling are given below.

- S Using improperly reprocessed or stored instruments may cause patient cross-contamination and infection.
- S Applying prolonged suction with the Distal End in contact with the mucosal surface may cause bleeding or suction lesions.
- S Inserting and using Endo-Therapy Accessories without a clear endoscopic view may cause burns or perforation.
- S Patient injury may be caused by; inserting or withdrawing the endoscope, applying suction without a clear endoscopic view; forcefully pulling, twisting or rotating the angulated Bending Section.

Chapter 1 Checking the Package Contents

1.1 Checking the Package Contents

Match all items in the package with the components shown below. Inspect each item for damages. If the instrument is damaged, a component is missing or you have any questions, do not use the instrument; immediately contact Olympus. This instrument was not disinfected or sterilized before shipment. Before using this instrument for the first time, reprocess it according to the instructions in Chapter 7, "Cleaning, Disinfection and Sterilization Procedures".

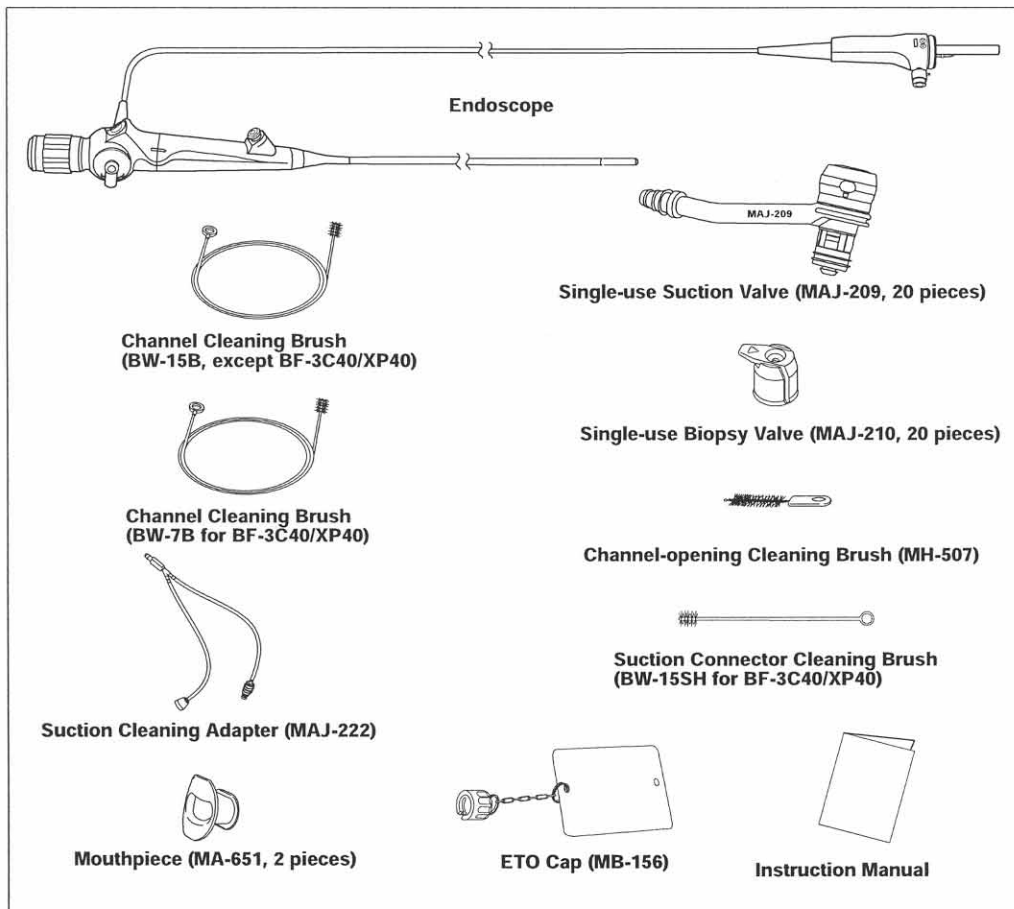

Chapter 2 Instrument Nomenclature and Specifications

2.1 Nomenclature

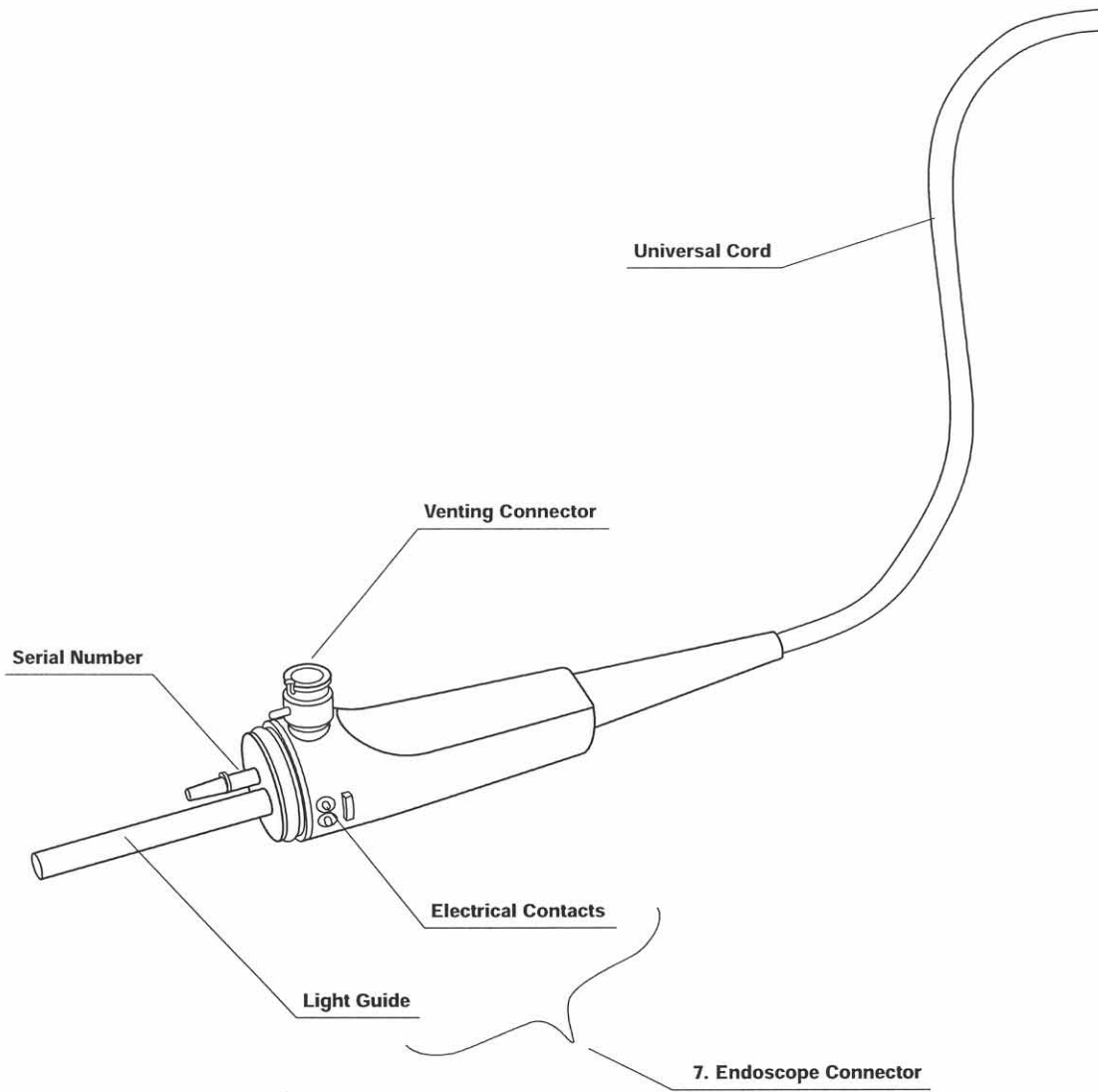

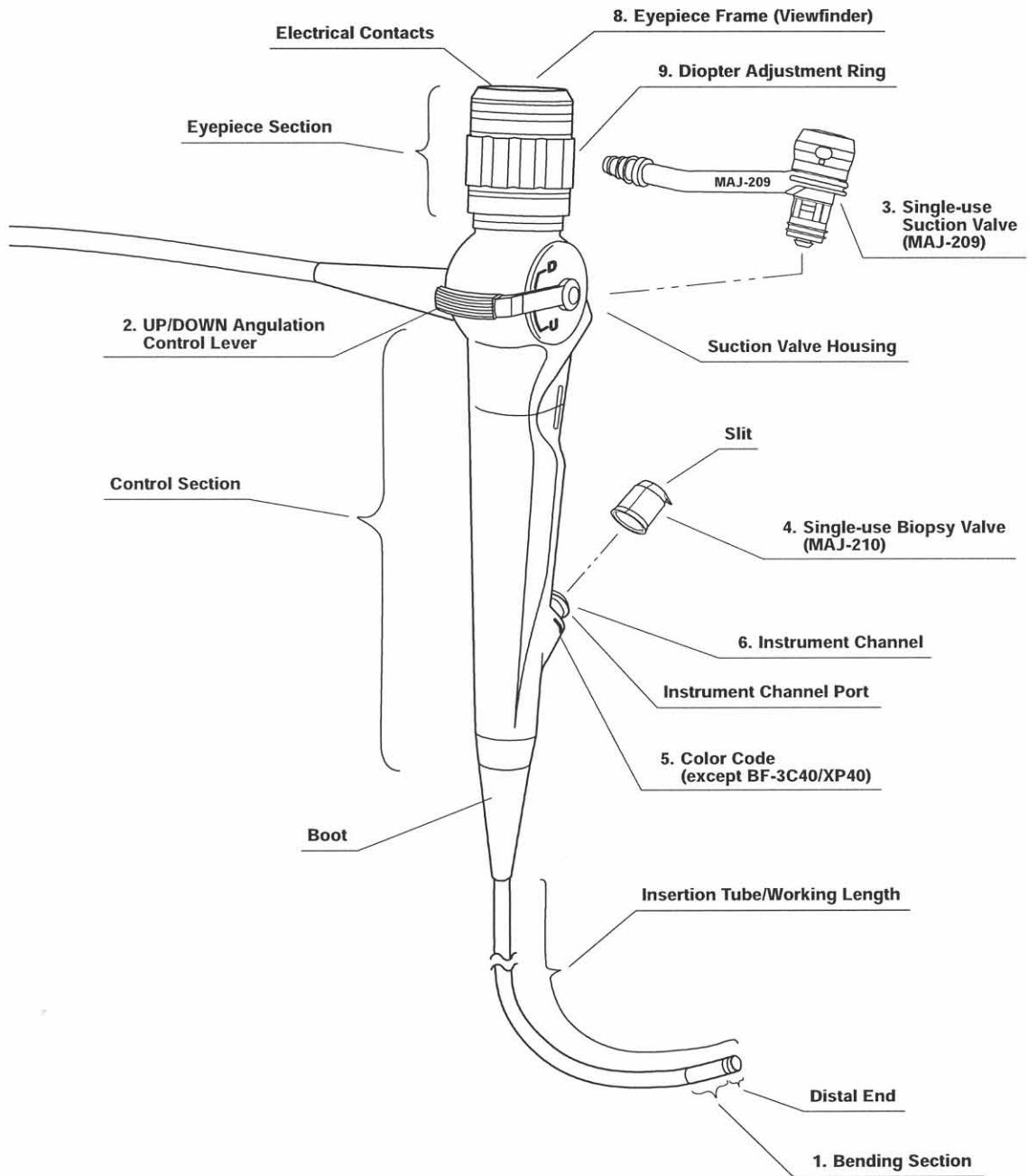

2.2 Endoscope Functions

1. Bending Section

Moves the Distal End of the endoscope by operating the UP/DOWN Angulation Control Lever.

2. UP/DOWN Angulation Control Lever

When turned in the "U" direction, the Bending Section moves UP; when turned in the "D" direction, the Bending Section moves DOWN.

3. Single-use Suction Valve

Depresses the valve to activate suction. Used to remove fluid and debris that obstruct the visual field.

WARNING The Single-use Suction Valve is designed for a single-use only. Do not attempt to reuse or resterilize.

4. Single-use Biopsy Valve (MAJ-210)

Accessories may be inserted through the Slit in this valve. A syringe may be inserted for the introduction of fluids.

WARNING The Single-use Biopsy Valve is designed for a single-use only. Do not attempt to reuse or resterilize.

5. Color Code

Used to quickly determine the compatibility of Endo-Therapy Accessories. (The endoscope can be used with Endo-Therapy Accessories that have the same color code.)

- § BF-40/P40 (Blue)
- § BF-1T40 (Green)
- § BF-XT40 (Yellow)

CAUTION BF-3C40/XP40 does not have a Color Code. If you use Endo-Therapy Accessories with BF-3C40/XP40, see the "System Chart" in the Appendix and select compatible Endo-Therapy Accessories.

6. Instrument Channel

Functions as: Channel for insertion of Endo-Therapy Accessories: Suction channel; fluid feed channel (from a syringe via the Biopsy Valve).

7. Endoscope Connector

Connects to the Light Source. Transmits light from the Light Source to the endoscope.

8. Eyepiece Frame (Viewfinder)

The Viewfinder contains an index mark indicating the UP direction of the Bending Section.

9. Diopter Adjustment Ring

Adjusts the operator's focus. This does not affect focusing for photography.

2.3 Specifications

Operating Environment

Operating Environment	Ambient Temperature	10 to 40°C (50 to 104°F)
	Relative Humidity	30 to 85%
	Air Pressure	700 to 1060 hPa (0.7 to 1.1 kgf/cm ²) (10.2 to 15.4 psia)

Specifications

BF-40

Optical System	Field of View	120°
	Depth of Field	3 to 50 mm
Insertion Tube	Distal End Outer Diameter	ø 5.8 mm
	Insertion Tube Outer Diameter	ø 5.9 mm
	Working Length	550 mm
Instrument Channel	Inner Channel Diameter	ø 2.2 mm
	Minimum Visible Distance	5 mm
	Direction from which Endo-Therapy Accessories enter and exit the endoscopic image	
Bending Section	Angulation Range	UP 180°, DOWN 130°
Total Length		840 mm

BF-P40

Optical System	Field of View	120°
	Depth of Field	3 to 50 mm
Insertion Tube	Distal End Outer Diameter	ø 4.9 mm
	Insertion Tube Outer Diameter	ø 5.0 mm
	Working Length	550 mm
Instrument Channel	Inner Channel Diameter	ø 2.2 mm
	Minimum Visible Distance	5 mm
	Direction from which Endo-Therapy Accessories enter and exit the endoscopic image	
Bending Section	Angulation Range	UP 180°, DOWN 130°
Total Length		840 mm

BF-1T40

Optical System	Field of View	120°
	Depth of Field	3 to 50 mm
Insertion Tube	Distal End Outer Diameter	ø 5.9 mm
	Insertion Tube Outer Diameter	ø 6.0 mm
	Working Length	550 mm
Instrument Channel	Inner Channel Diameter	ø 2.8 mm
	Minimum Visible Distance	5 mm
	Direction from which Endo-Therapy Accessories enter and exit the endoscopic image	
Bending Section	Angulation Range	UP 180°, DOWN 130°
Total Length		840 mm

BF-XT40

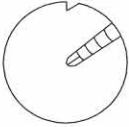
Optical System	Field of View	120°
	Depth of Field	3 to 50 mm
Insertion Tube	Distal End Outer Diameter	ø 6.1 mm
	Insertion Tube Outer Diameter	ø 6.2 mm
	Working Length	550 mm
Instrument Channel	Inner Channel Diameter	ø 3.2 mm
	Minimum Visible Distance	5 mm
	Direction from which Endo-Therapy Accessories enter and exit the endoscopic image	
Bending Section	Angulation Range	UP 180°, DOWN 130°
Total Length		840 mm

BF-3C40

Optical System	Field of View	120°
	Depth of Field	3 to 50 mm
Insertion Tube	Distal End Outer Diameter	ø 3.3 mm
	Insertion Tube Outer Diameter	ø 3.6 mm
	Working Length	550 mm
Instrument Channel	Inner Channel Diameter	ø 1.2 mm
	Minimum Visible Distance	3 mm
	Direction from which Endo-Therapy Accessories enter and exit the endoscopic image	
Bending Section	Angulation Range	UP 180°, DOWN 130°
Total Length		840 mm

BF-XP40

Optical System	Field of View	90°
	Depth of Field	2 to 50 mm
Insertion Tube	Distal End Outer Diameter	ø 2.8 mm
	Insertion Tube Outer Diameter	ø 2.8 mm
	Working Length	600 mm
Instrument Channel	Inner Channel Diameter	ø 1.2 mm
	Minimum Visible Distance	1.5 mm
	Direction from which Endo-Therapy Accessories enter and exit the endoscopic image	
Bending Section	Angulation Range	UP 180°, DOWN 130°
	Total Length	890 mm
Year of manufacture	1912345	<p>↑</p> <p>The last digit of the year of manufacture is given in the second digit of the serial number.</p>
Degree of protection against electric shock		TYPE BF applied part

Chapter 3 Preparation and Inspection

WARNING

- S Before each case, prepare and inspect this instrument as instructed below. Inspect other equipment that are used with this instrument as instructed in their respective instruction manuals. Should the slightest irregularity be suspected, do not use this instrument and see Chapter 10, "Troubleshooting". If the irregularity is still suspected after consulting Chapter 10, contact Olympus. Damage or irregularity may compromise patient or user safety and may result in more-severe equipment damage.
- S This instrument was not disinfected or sterilized before shipment. Before using this instrument for the first time, reprocess it according to the instructions in Chapter 7, "Cleaning, Disinfection and Sterilization Procedures".

3.1 Preparation of the Equipment

According to the "System Chart" in the Appendix, prepare this instrument, ancillary equipment, paper towels, basin, lint-free cloth and personal protective equipment, such as eye wear, a face mask, moisture-resistant clothing and chemical-resistant gloves, for the particular case. Refer to the respective instruction manual for each piece of equipment.

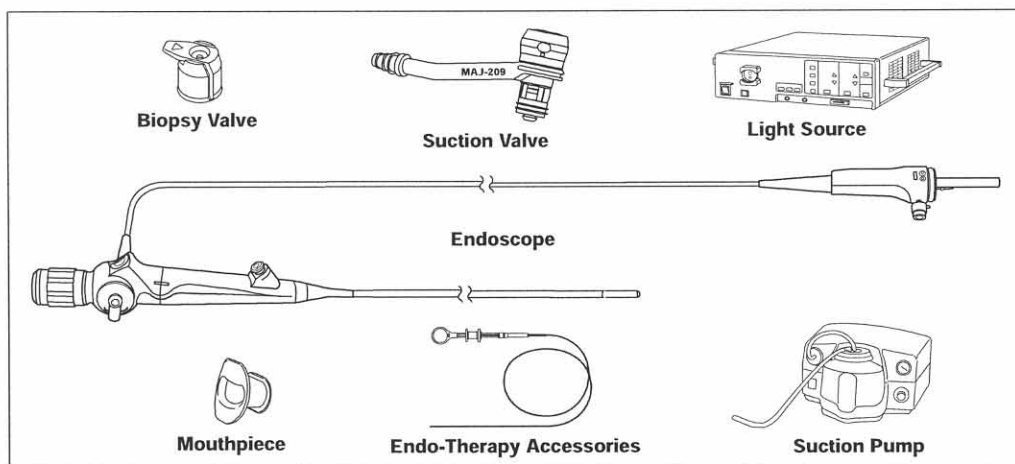

Figure 3.1

3.2 Preparation and Inspection of the Endoscope

Clean and disinfect (or sterilize) the endoscope as described in Chapters 5 through 8 of this instruction manual.

Inspection of the Endoscope

1. Visually inspect the Control Section and the Endoscope Connector for excessive scratching.
2. Visually inspect the Boot and the Insertion Tube near the Boot for bends, twists or other irregularities.
3. Visually inspect the surface of the Insertion Tube for dents, bulges, swelling or other irregularities.
4. Carefully run your fingertips over the entire length of the Insertion Tube. Inspect for any protruding objects or other irregularities. (See Figure 3.2)

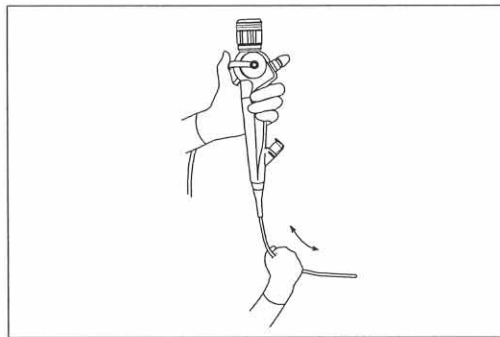

Figure 3.2

5. Visually inspect the covering of the Bending Section for sagging, swelling, cuts, holes or other irregularities.
6. Loosely hold the midpoint of the Bending Section and a point 10 cm from the Distal End. Push and pull gently to confirm that there is no play.
7. Visually inspect the Objective Lens at the Distal End of the endoscope for dents, bulges, swelling or other irregularities.
8. Confirm that the Diopter Adjustment Ring turns smoothly and that the Eyepiece Section is attached securely to the Control Section. Confirm that the eyepiece is free of defects, such as scratches or deformations.

CAUTION When cleaning or wiping the eyepiece lens surface, do not use abrasive cleansers because they may scratch the lens surface.

9. Wipe the Eyepiece Section, the Electrical Contacts and Light Guide edges of the Endoscope Connector using a clean, lint-free cloth moistened with 70% ethyl or isopropyl alcohol.

Inspection of the Bending Mechanisms

Perform the following inspections while the Bending Section is straight.

Inspection for Smooth Operation

1. Turn the UP/DOWN Angulation Control Lever slowly in each direction until it stops. Confirm that the Bending Section angulates smoothly and correctly and that maximum direction can be achieved.
2. Turn the UP/DOWN Angulation Control Lever slowly to its neutral position. Confirm that the Bending Section returns smoothly to an approximately straight condition.

3.3 Preparation and Inspection of Accessories

Prepare the Single-use Suction Valve (MAJ-209) and Single-use Biopsy Valve (MAJ-210).

Inspection of the Suction Valve

CAUTION This valve is provided sterile. Do not open the package until ready to use.

Inspect the Suction Valve for damage. (See Figure 3.3)

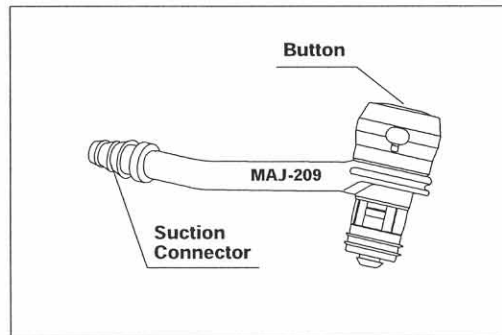

Figure 3.3

- NOTE**
- § Only the Single-use Suction Valve (MAJ-209) should be used with this endoscope.
 - § This valve is designed for use with BF-30, 40, 200 and 240 Series endoscopes.

Inspection of the Biopsy Valve

CAUTION This valve is provided sterile. Do not open the package until ready to use.

Inspect the Biopsy Valve for damage. (See Figure 3.4)

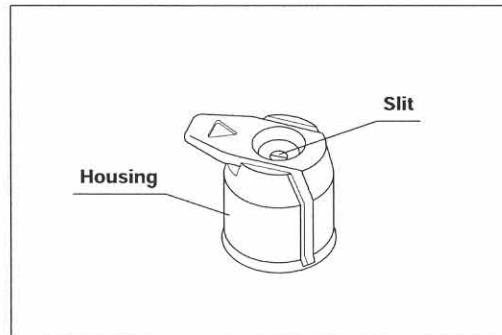

Figure 3.4

- NOTE**
- § Only the Single-use Biopsy Valve (MAJ-210) should be used with this endoscope.
 - § This valve is designed for use with BF-30, 40, 200 and 240 Series endoscopes.

3.4 Attaching Accessories to the Endoscope

Attaching the Suction Valve

1. Place the Suction Valve into the Suction Valve Housing, aligning the arm of the main body with the white index mark on the endoscope. (See Figure 3.5)
2. Push down on the top of the Suction Valve with your finger until it clicks into position. Confirm that the valve is secure and operates smoothly.

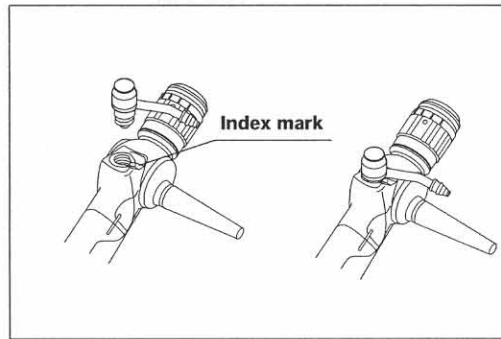

Figure 3.5

NOTE

Sometimes the Suction Valve will click before it is fully seated in the Suction Valve Housing. Press down firmly on the Suction Valve with your finger to insure that it is fully seated in the Suction Valve Housing.

Attaching the Biopsy Valve

Push the Biopsy Valve (MAJ-210) down onto the Instrument Channel Port until the valve snaps into position. Confirm that the valve is secure. (See Figure 3.6)

NOTE

At low temperatures, the Biopsy Valve may become stiff and difficult to attach.

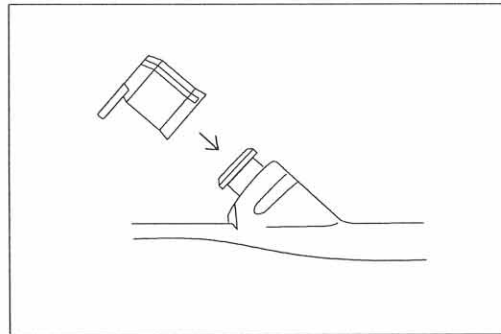

Figure 3.6

3.5 Preparation, Inspection and Connection of the Ancillary Equipment

Preparation and Inspection of Ancillary Equipment

Prepare and inspect the Light Source, Suction Pump and Endo-Therapy Accessories according to their respective instruction manuals.

Connection of the Endoscope and Ancillary Equipment

1. Insert the Endoscope Connector completely into the output socket of the Light Source.
2. Connect the suction pump tube from the Suction Pump to the Suction Connector on the Suction Valve.

If required, prepare and inspect the camera, display monitor and video system according to their respective instruction manuals.

3.6 Inspection of the Endoscopic System

Inspection of the Endoscopic Image

1. Turn the power switch of the Light Source ON according to the instruction manual for the Light Source. If you are using the EVIS Universal Light Source, set the Mode switch to "OES".
2. Adjust the brightness level as appropriate.
3. Turn the Diopter Adjustment Ring until the fiber pattern is clear. Confirm that an object approximately 15 mm from the Objective Lens can be seen clearly.

NOTE

If the object cannot be seen clearly, wipe the Objective Lens and the eyepiece lens using a clean, lint-free cloth moistened with 70% ethyl or isopropyl alcohol.

Inspection of the Suction Function

WARNING Aspirate with a pressure of 670 hPa (0.68 kgf/cm², 9.7 psia) or less. Excessive pressure may make it difficult to stop suction.

1. Immerse the Distal End of the Insertion Tube in sterile water and depress the Suction Valve. Confirm that water is continuously aspirated into the suction bottle of the Suction Pump.
2. Release the valve. Confirm that suction stops and the valve returns to its original position.
3. Remove the Distal End of the Insertion Tube from the water. Depress the valve and aspirate air for a few seconds to remove water from the channel.

Inspection of the Water Feed

1. Insert a syringe filled with sterile water into the Slit of Biopsy Valve and depress the plunger.
2. Confirm that water is emitted from the Distal End.

NOTE

- § The syringe must be inserted fully and held perpendicular to the valve for proper operation. Angled or incomplete insertion may result in fluid leakage from the Biopsy Valve.
- § Do not depress the Suction Valve during feeding. If the Suction Valve is depressed during water feeding, water will be aspirated into the suction tube and not emitted from the endoscope's Distal End.
- § If fluid is not emitted from the endoscope's Distal End, flush air through the channel.

Chapter 4 Operation

The operator of this instrument must be a physician or medical personnel under the supervision of a physician and must have received sufficient training in clinical endoscopic technique. This manual, therefore, does not explain or discuss clinical endoscopic procedures. It only describes basic operation and precautions related to the operation of this instrument.

WARNING

- S Anytime you suspect an abnormality in an endoscope function, stop the examination immediately and slowly remove it while viewing the endoscopic image. Using a defective endoscope may cause patient injury.
- S If the endoscopic image should unexpectedly disappear, stop the examination immediately. Without touching the Angulation Control Lever, slowly withdraw the endoscope from the patient. If an Endo-Therapy Accessory is being used, withdraw it in the safest possible manner before withdrawing the endoscope.
- S If the angulation control mechanism or any other part of the system is not functioning properly, stop the procedure immediately; do not operate the Angulation Control Lever unless absolutely necessary. Then carefully withdraw the endoscope while observing the endoscopic image. If the endoscope cannot be withdrawn from the patient smoothly, do not attempt to forcibly withdraw it; leave it inside the patient and immediately contact Olympus. Forcibly withdrawing the endoscope may cause patient injury.
- S Use personal protective equipment to guard against dangerous chemicals and potentially infectious material. During operation, wear appropriate protective equipment, such as eye wear, a face mask, moisture-resistant clothing and chemical-resistant gloves that fit properly and are long enough so that your skin is not exposed.

4.1 Insertion

Holding and Manipulating the Endoscope

The Control Section of the endoscope is designed to be held in the left hand. The Suction Valve can be operated using the left index finger. The UP/DOWN Angulation Control Lever can be operated using the left thumb. The right hand is free to manipulate the Insertion Tube. (See Figure 4.1)

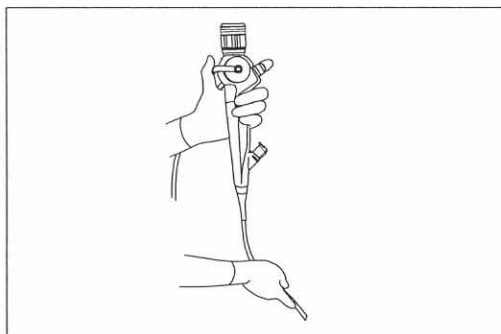

Figure 4.1

Insertion of the Endoscope

1. If necessary, apply a medical-grade, water-soluble lubricant to the Insertion Tube.

CAUTION Do not apply olive oil or products containing petroleum-based lubricants (e.g. Vaseline). These products may cause stretching and deterioration of the Bending Section's covering.

2. Place the Mouthpiece in the patient's mouth.

CAUTION To prevent the patient from accidentally biting the Insertion Tube, it is recommended that a Mouthpiece be placed in the patient's mouth before inserting the endoscope.

3. Always view the endoscopic image when passing the Distal End of the endoscope from the mouth to the larynx.

CAUTION Do not allow the Insertion Tube to bend in a radius of 10 cm or less at the junction of the Boot. Insertion Tube damage can occur. (See Figure 4.2)

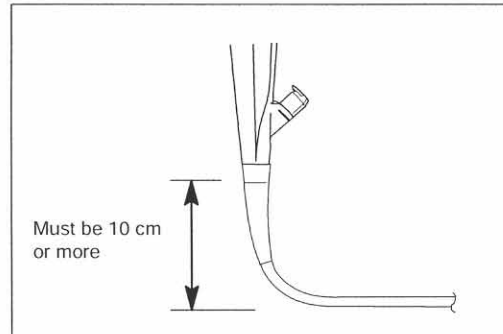

Figure 4.2

Angulation of the Distal End

WARNING If the angulation control mechanism or any other part of the system is not functioning properly, stop the procedure immediately; do not operate the Angulation Control Lever unless absolutely necessary. Then carefully withdraw the endoscope while observing the endoscopic image. If the endoscope cannot be withdrawn from the patient smoothly, do not attempt to forcibly withdraw it; leave it inside the patient and immediately contact Olympus. Forcibly withdrawing the endoscope may cause patient injury.

Operate the Angulation Control Lever as necessary to guide the Distal End for the insertion and observation.

Feeding and Aspirating Fluids

Feeding

Securely insert a syringe into the Slit of Biopsy Valve and press the plunger.

CAUTION Do not depress the Suction Valve during feeding. If the Suction Valve is depressed during feeding, fluids will be aspirated into the Suction Pump.

Aspiration

WARNING Avoid aspiration solid matter or thick fluids, channel or valve clogging can occur. If the Suction Valve clogs and aspiration cannot be turned off, disconnect the suction tube from the Suction Connector of Suction Valve. Stop the procedure and withdraw the endoscope from the patient.

CAUTION During the procedure, make sure that the suction bottle does not fill completely or overflow. Aspirating fluids into a full container can damage the Suction Pump.

Depress the Suction Valve to aspirate excess fluids or debris. (See Figure 4.3)

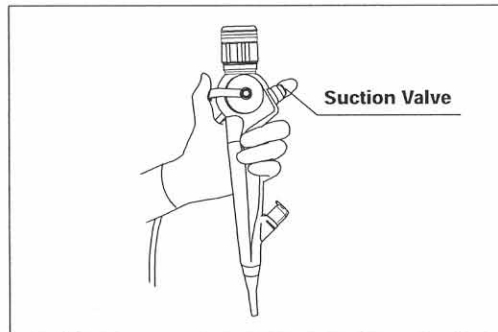

Figure 4.3

Observation of the Endoscopic Image

WARNING

The Distal End of the endoscope may exceed 41°C (106°F) and reach 50°C (122°F) due to intense endoscopic illumination. Surface temperatures over 41°C (106°F) may cause mucosal burns. Always use the minimum level of illumination necessary for adequate viewing. Whenever possible, avoid close stationary viewing and do not leave the Distal End of the endoscope close to mucous membrane for a long time.

Refer to the Light Source's instruction manual for instructions on how to adjust the brightness.

Photography

Connect the camera to the endoscope's eyepiece, and take photographs according to the camera's instruction manual.

Monitor Observation

When observing the endoscopic image on the display monitor, refer to the instruction manuals of the Light Source and the OES Video System.

NOTE

If you are using the EVIS Video System Center, the OES Video Converter makes it possible to observe the endoscopic image on the display monitor.

Simultaneous Observation by 2 People

By connecting the Lecturescope (LS-10) to the endoscope's eyepiece a second observer may view the procedure.

4.2 Using Endo-Therapy Accessories

For information on combining the endoscope with particular Endo-Therapy Accessories, read the instruction manuals for Endo-Therapy Accessories.

WARNING

If an Endo-Therapy Accessory cannot be withdrawn from the endoscope, close the tip of the Endo-Therapy Accessory or retract the tip of the Endo-Therapy Accessory into its sheath and slowly withdraw the endoscope while observing the endoscopic image.

Insertion of Endo-Therapy Accessories Into the Endoscope

1. Refer to the "System Chart" in the Appendix to determine instrument compatibility.
2. While holding the UP/DOWN Angulation Control Lever stationary, slowly insert the Endo-Therapy Accessory through the Slit of Biopsy Valve.

CAUTION

- S If significant resistance is encountered and insertion becomes very difficult, straighten the Bending Section as much as possible without losing the endoscopic view. Inserting Endo-Therapy Accessories with excessive force may damage the endoscope.
 - S Confirm that the tip of the Endo-Therapy Accessory is closed or retracted into its sheath and slowly insert the Endo-Therapy Accessory into the Biopsy Valve. Do not open the tip of the Endo-Therapy Accessory or extend the tip of the Endo-Therapy Accessory from the its sheath while inserting the Endo-Therapy Accessory into the channel. The channel and/or the Endo-Therapy Accessory may become damaged.
 - S Hold the Endo-Therapy Accessory close to the Biopsy Valve and insert it straight into the Biopsy Valve using slow short strokes. Otherwise, the Endo-Therapy Accessory could bend or break.
3. Hold the Endo-Therapy Accessory approximately 4 cm from the Biopsy Valve and slowly advance the accessory using slow, short strokes.

Operation of Endo-Therapy Accessories

Operate the Endo-Therapy Accessory according to the directions given in its instruction manual.

Withdrawal of Endo-Therapy Accessories

Withdraw the Endo-Therapy Accessory slowly while the tip of the Endo-Therapy Accessory is closed and/or retracted into its sheath.

WARNING Do not withdraw the Endo-Therapy Accessory if the tip is opened or extended from its sheath; patient injury and/or instrument damage may occur. If the Endo-Therapy Accessory cannot be withdrawn, carefully withdraw both the endoscope and the Endo-Therapy Accessory together under endoscopic observation. Take care not to cause tissue trauma.

High Frequency Cauterization

WARNING

- S Never perform electrosurgery with BF-3C40/XP40, because the Distal End of this instrument is not insulated. Patient injury can result.
- S Do not perform electrosurgery while supplying oxygen. This may result in combustion during cauterization.

CAUTION

- S Always confirm that the electrode section of the Electrosurgical Accessory is at an appropriate distance from the Distal End of the endoscope. Confirm that the green marking at the distal tip of the Electrosurgical Accessory can be observed on the endoscopic image (See Figure 4.4). If the electrode is used when too close to the Distal End of endoscope, the endoscope and/or ancillary equipment may be damaged. Using an damaged endoscope may cause patient injury.
- S Set the output level of the electrosurgical unit to the minimum necessary level. If the output level is set too high, the endoscope's and accessory's insulation may be damaged and cause operator and/or patient burns. Furthermore, it is recommended that you conduct basic experiments before electrosurgery according to the instruction manual of Electrosurgical Unit.

- S Before electrosurgery, visually inspect the surface of the endoscope for any dents, bulges or other irregularities.
- S When performing electrosurgery, do not use the SPRAY coagulation mode. The endoscope may be damaged.

Prepare, inspect and connect the Electrosurgical Unit and Electrosurgical Accessories according to their instruction manuals.

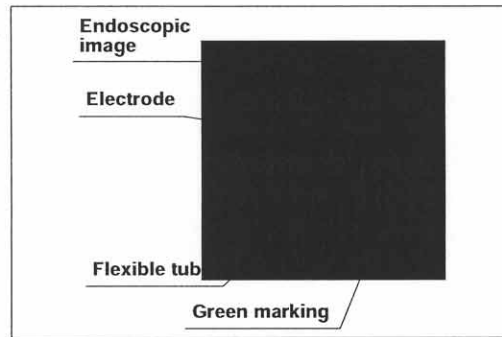

Figure 4.4

NOTE

- S The outer surfaces of the BF-40 series endoscopes (except BF-3C40/XP40) are insulated. This allows electrosurgery to be performed.
- S Some Olympus endoscopes are equipped with a feedback circuit to provide endoscope leakage current from the Electrosurgical Accessory to the electrosurgical unit. However, the BF-40 series is not equipped with the feedback circuit because leakage current from the Electrosurgical Accessory to the endoscope is little as the insertion part is short. Therefore, the S-CORD is unnecessary.
- S When using the Electrosurgical Unit Olympus PSD-10, the following P-CORD is necessary: The S-P CORD is unnecessary.
 - P-CORD (MB-582)
 - P-CORD for disposable patient plate (MB-584)

Laser Cauterization

WARNING

- S Do not perform laser cauterization while supplying oxygen. This may result in combustion during cauterization.
- S To avoid patient injury and/or damage to the endoscope, never emit laser radiation before confirming that an appropriate distance between the target and the endoscope's Distal End is maintained and the tip of the laser probe is in the correct position in the endoscopic image.
- S When using an endotracheal tube keep an appropriate distance between the endoscope's Distal End and the endotracheal tube. Then confirm that the endoscope's Distal End extends enough from the endotracheal tube to allow angulation control. If the laser is activated while the Distal End is too close to the endotracheal tube, patient injury and/or equipment damage may occur.
- S Allow the tip of the Laser Probe to cool before withdrawing it from the channel. If the Laser Probe is withdrawn while hot, channel damage may occur.
- S Do not use a damaged Laser Probe. A Laser Probe with a damaged sheath or a distal end, may cause patient injury and/or equipment damage.

CAUTION

Before inserting or withdrawing the Laser Probe, move the UP/DOWN Angulation Control Lever to its neutral position so that the Bending Section will become straight. If it is bent, there is a danger of damaging the Instrument channel.

Prepare, inspect and connect the Laser Unit and Laser Probe according to their instruction manuals.

Bronchoalveolar Lavage

Using the BAL (Bronchoalveolar Lavage) Kit

1. Disconnect the suction tube from the Suction Connector of the Suction Valve. Connect the suction tube from the Suction Pump to the suction connector of a commercially available BAL Kit. Connect the BAL Kit's suction line to the Suction Connector of Suction Valve. (See Figure 4.5)

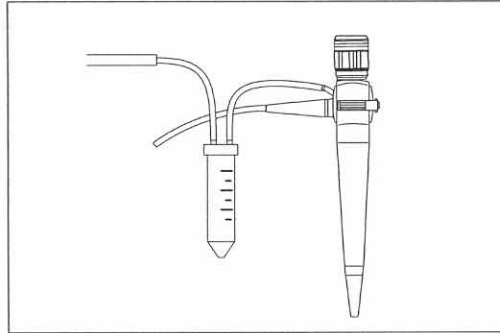

Figure 4.5

2. Securely insert a syringe filled with lavage fluid (e.g. saline) into the Slit of the Biopsy Valve and press the plunger to feed lavage fluid.
3. Depress the Suction Valve to aspirate lavage fluid.

Using a Syringe

1. Securely insert a syringe filled with lavage fluid (e.g. saline) into the Slit of the Biopsy Valve and press the plunger to feed lavage fluid. (See Figure 4.6)
2. With the syringe attached, slowly withdraw the plunger to aspirate lavage fluid. (See Figure 4.6)

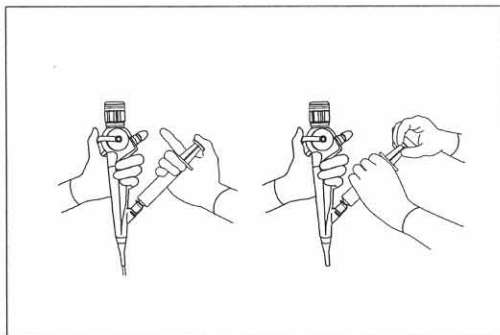

Figure 4.6

4.3 Withdrawal of the Endoscope

1. Slowly withdraw the endoscope while observing the endoscopic image.
2. Remove the Mouthpiece from the patient's mouth.

4.4 Transportation of the Endoscope

Transporting Within the Hospital

When carrying the endoscope, hold the Endoscope Connector together with the Control Section in one hand and hold the Distal End of the Insertion Tube securely, but lightly without squeezing, in the other hand as shown in Figure 4.7.

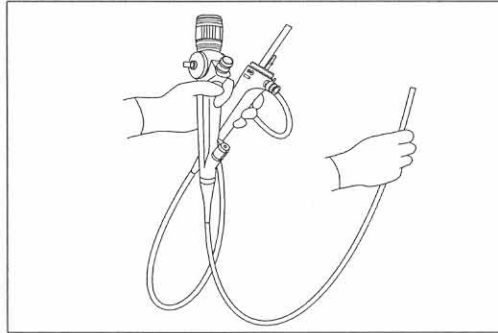

Figure 4.7

Transporting Outside the Hospital

Transport the endoscope in the Carrying Case.

- CAUTION**
- S The Carrying Case cannot be cleaned or disinfected. Clean and disinfect or sterilize the endoscope before placing it in the Carrying Case. Disinfect or sterilize the endoscope again before use.
 - S Attach the ETO Cap when transporting the endoscope, to avoid damage caused to the endoscope by change in air pressure.

Chapter 5 **Reprocessing: General Policy**

5.1 **Instructions**

- § Chapters 5 through 8 describe recommended procedures for cleaning and disinfecting or sterilizing this instrument.
- § The medical literature reports incidents of patient cross contamination resulting from improper cleaning, disinfection or sterilization. It is strongly recommended that reprocessing personnel have a thorough understanding of and follow all national and local hospital guidelines and policies.
A specific individual or individuals in the endoscopy unit should be responsible for reprocessing endoscopic equipment. It is highly desirable that a trained backup be available should the primary reprocessing individual(s) be absent.
- § All individuals responsible for reprocessing should thoroughly understand:
 - § your institution's reprocessing procedures
 - § occupational health and safety regulations
 - § national and local hospital guidelines and policies
 - § the instructions in this manual
 - § the mechanical aspects of endoscopic equipment
 - § pertinent germicide labeling

5.2 Precautions

WARNING

- S Failure to properly clean and high-level disinfect or sterilize endoscopic equipment after each examination can compromise patient safety. To minimize the risk of transmitting diseases from one patient to another, the endoscope must undergo thorough manual cleaning followed by high-level disinfection or sterilization after each examination.
- S If the endoscope is not cleaned meticulously, effective disinfection (or sterilization) may not be possible. Clean the endoscope and accessories thoroughly before disinfection or sterilization to remove microorganisms or organic material that could reduce the efficacy of disinfection or sterilization.
- S Patient debris and reprocessing chemicals are hazardous. Wear personal protective equipment to guard against dangerous chemicals and potentially infectious material. During cleaning and disinfection (or sterilization), wear appropriate protective equipment, such as eye wear, face mask, moisture-resistant clothing and chemical-resistant gloves that fit properly and are long enough so that your skin is not exposed. Always remove contaminated protective equipment before leaving the cleaning area.
- S Thoroughly rinse off the disinfectant solution. Rinse the outer surface of the endoscope, channels and cleaning equipment thoroughly with water to remove the disinfectant solution residue.
- S The disinfection/sterilization room must be adequately ventilated. Adequate ventilation protects against toxic chemical fumes.
- S Store alcohol in an air-tight container. Alcohol stored in an open container may cause fires and will lose its efficacy due to evaporation.

CAUTION

- S When aerating or irrigating the endoscope channels, the air or water pressure must not exceed 0.2 MPa (2 kgf/cm², 29 psia).
- S Before immersing the endoscope in cleaning or disinfectant solution, confirm that the ETO Cap is not attached to the Endoscope Connector.

Chapter 6 Compatible Reprocessing Methods and Chemical Agents

6.1 Compatibility Summary

Olympus endoscopic equipment is compatible with several methods of reprocessing. Certain components and accessories, however, are not compatible with some methods, which can cause equipment damage. For appropriate reprocessing methods, refer to Table 6.1 below, the recommendations of your infection control committee and national and local hospital guidelines and policies.

	Steam Sterilization (Autoclaving)	ETO Gas Sterilization	2 to 3.2% Glutaraldehyde	70% Ethyl or Isopropyl Alcohol	Detergent Solution	Ultrasonic Cleaning
Endoscope						
ETO Cap (MB-156)						
Channel Cleaning Brush (BW-15B/7B)						
Suction Connector Cleaning Brush (BW-15SH)						
Channel-opening Cleaning Brush (MH-507)						
Suction Cleaning Adapter (MAJ-222)						
Mouthpiece (MA-651)						



 Applicable  Not applicable

Table 6.1

4.4 Transportation of the Endoscope

Transporting Within the Hospital

When carrying the endoscope, hold the Endoscope Connector together with the Control Section in one hand and hold the Distal End of the Insertion Tube securely, but lightly without squeezing, in the other hand as shown in Figure 4.7.

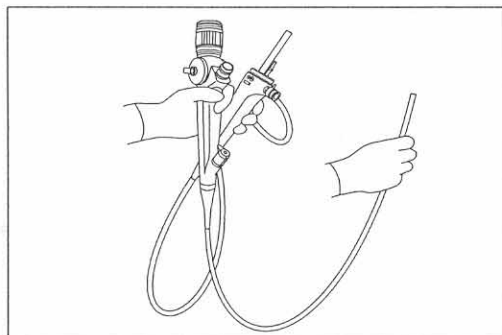

Figure 4.7

Transporting Outside the Hospital

Transport the endoscope in the Carrying Case.

CAUTION

- S The Carrying Case cannot be cleaned or disinfected. Clean and disinfect or sterilize the endoscope before placing it in the Carrying Case. Disinfect or sterilize the endoscope again before use.
- S Attach the ETO Cap when transporting the endoscope, to avoid damage caused to the endoscope by change in air pressure.

Chapter 5 **Reprocessing: General Policy**

5.1 **Instructions**

- § Chapters 5 through 8 describe recommended procedures for cleaning and disinfecting or sterilizing this instrument.
- § The medical literature reports incidents of patient cross contamination resulting from improper cleaning, disinfection or sterilization. It is strongly recommended that reprocessing personnel have a thorough understanding of and follow all national and local hospital guidelines and policies.
A specific individual or individuals in the endoscopy unit should be responsible for reprocessing endoscopic equipment. It is highly desirable that a trained backup be available should the primary reprocessing individual(s) be absent.
- § All individuals responsible for reprocessing should thoroughly understand:
 - § your institution's reprocessing procedures
 - § occupational health and safety regulations
 - § national and local hospital guidelines and policies
 - § the instructions in this manual
 - § the mechanical aspects of endoscopic equipment
 - § pertinent germicide labeling

5.2 Precautions

WARNING

- S Failure to properly clean and high-level disinfect or sterilize endoscopic equipment after each examination can compromise patient safety. To minimize the risk of transmitting diseases from one patient to another, the endoscope must undergo thorough manual cleaning followed by high-level disinfection or sterilization after each examination.
- S If the endoscope is not cleaned meticulously, effective disinfection (or sterilization) may not be possible. Clean the endoscope and accessories thoroughly before disinfection or sterilization to remove microorganisms or organic material that could reduce the efficacy of disinfection or sterilization.
- S Patient debris and reprocessing chemicals are hazardous. Wear personal protective equipment to guard against dangerous chemicals and potentially infectious material. During cleaning and disinfection (or sterilization), wear appropriate protective equipment, such as eye wear, face mask, moisture-resistant clothing and chemical-resistant gloves that fit properly and are long enough so that your skin is not exposed. Always remove contaminated protective equipment before leaving the cleaning area.
- S Thoroughly rinse off the disinfectant solution. Rinse the outer surface of the endoscope, channels and cleaning equipment thoroughly with water to remove the disinfectant solution residue.
- S The disinfection/sterilization room must be adequately ventilated. Adequate ventilation protects against toxic chemical fumes.
- S Store alcohol in an air-tight container. Alcohol stored in an open container may cause fires and will lose its efficacy due to evaporation.

CAUTION

- S When aerating or irrigating the endoscope channels, the air or water pressure must not exceed 0.2 MPa (2 kgf/cm², 29 psia).
- S Before immersing the endoscope in cleaning or disinfectant solution, confirm that the ETO Cap is not attached to the Endoscope Connector.

Chapter 6 Compatible Reprocessing Methods and Chemical Agents

6.1 Compatibility Summary

Olympus endoscopic equipment is compatible with several methods of reprocessing. Certain components and accessories, however, are not compatible with some methods, which can cause equipment damage. For appropriate reprocessing methods, refer to Table 6.1 below, the recommendations of your infection control committee and national and local hospital guidelines and policies.

	Steam Sterilization (Autoclaving)	ETO Gas Sterilization	2 to 3.2% Glutaraldehyde	70% Ethyl or Isopropyl Alcohol	Detergent Solution	Ultrasonic Cleaning
Endoscope						
ETO Cap (MB-156)						
Channel Cleaning Brush (BW-15B/7B)						
Suction Connector Cleaning Brush (BW-15SH)						
Channel-opening Cleaning Brush (MH-507)						
Suction Cleaning Adapter (MAJ-222)						
Mouthpiece (MA-651)						

Applicable
 Not applicable

Table 6.1

CAUTION Endo-Therapy Accessories and other items which are marked by the words "AUTOCLAVE" or "AUTOCLAVABLE", a green band or yellow-green marking are compatible with autoclaving.

6.2 Detergent Solution

Use a medical-grade, low-foaming, neutral pH detergent or enzymatic detergent and follow the manufacturer's dilution and temperature recommendations. Contact Olympus for the names of specific brands that have been tested for compatibility with the endoscope. Do not reuse detergent solutions.

WARNING Excessive detergent foaming can prevent fluid from adequately contacting internal lumens (e.g. channels).

6.3 Disinfectant Solution

In the U.S., agents used to achieve high-level disinfection are defined as liquid chemical germicides registered with the Environmental Protection Agency as "sterilant/disinfectants" which are used according to the time, temperature and dilution recommended by the disinfectant manufacturer for achieving high-level disinfection. These conditions usually coincide with those recommended by the disinfectant manufacturer for 100% kill of *Mycobacterium tuberculosis*.

In general, 2.0% to 3.2% glutaraldehyde solutions, when used according to the manufacturer's instructions for achieving high-level disinfection, are compatible with Olympus endoscopes. Contact Olympus for the names of specific brands that have been tested for compatibility with this endoscope.

If the disinfectant solution is reused, routinely check its efficacy with a test strip recommended by the manufacturer. Do not use solutions beyond their expiration date.

WARNING Alcohol is not a sterilant or high-level disinfectant.

6.4 Rinsing Water

Once removed from the disinfectant solution, the instrument must be thoroughly rinsed with sterile water to remove any disinfectant residue. If sterile water is not available, clean potable tap water or water which has been processed (e.g. filtered) to improve its microbiological quality may be used.

When non-sterile water is used after manual or automated disinfection, wipe the endoscope and flush the channels with 70% ethyl or isopropyl alcohol, then air-dry all internal channels to inhibit the growth of residual bacteria. Do not reuse rinsing water.

6.5 ETO Gas Sterilization

This instrument or other accessories compatible with ETO gas sterilization as shown in Table 6.1 can be sterilized by ethylene oxide gas and aerated within the parameters given in Table 6.2. When performing sterilization, follow the hospital's protocol and the sterilization equipment manufacturer's instructions.

WARNING

- S Before sterilization, the instrument must be thoroughly cleaned and dried. Residual moisture inhibits sterilization.
- S Use biological indicators as recommended by your hospital's policy, and follow the manufacturer's instructions, all national and local hospital guidelines and policies.
- S All instruments must be properly aerated following ETO gas sterilization to remove toxic ethylene oxide residuals.

- CAUTION**
- S Attach the ETO Cap to the Endoscope Connector before sterilizing. If the ETO Cap is not attached on the endoscope during sterilization, the vacuum created within the sterilization chamber can rupture the covering of the Bending Section.
 - S Repeated ETO gas sterilization procedures will gradually deteriorate the instrument. Do not perform ETO gas sterilization to the instrument unnecessarily.

ETO Gas Exposure Parameters (Gas mixture 12% ETO/88% CFC)

Process	Parameters	
ETO Gas Sterilization	Temperature	57°C (135°F)
	Pressure	0.1 to 0.17 MPa (1.0 to 1.7 kgf/cm ² , 16 to 24 psia)
	Humidity	55%
	Exposure Time	1.75 hours
	ETO Gas Concentration	600 to 700 mg/l
Aeration (Minimum)	12 hours in an aeration chamber at 50 to 57°C (122 to 135°F) or 7 days at room temperature	

Table 6.2

6.6 Steam Sterilization (Autoclaving) of Accessories

Steam sterilize (autoclave) within the parameters given in Table 6.3 below. When steam sterilizing, follow the hospital's protocol and the sterilization equipment manufacturer's instructions. Prior to steam sterilization (autoclaving) of accessories, meticulous manual cleaning followed by at least 5 minutes of ultrasonic cleaning at 38 to 47 kHz is required.

- WARNING**
- S Exceeding the recommended parameters may cause equipment damage.
 - S Use biological indicators as recommended by your hospital's policy, and follow the manufacturer's instructions, all national and local hospital guidelines and policies.

- CAUTION**
- S Do not steam sterilize the endoscope. Steam sterilization (autoclaving) will severely damage the endoscope.
 - S Effective sterilization will not be possible if items are packed tightly together in the autoclave; always pack items loosely.
 - S Inspect the packages for openings, tears and other damage. If the packages are open or damaged, seal the components in new packaging and re-sterilize as described below.
 - S Allow the packages to dry within the autoclave, using the autoclave's drying cycle (if available) or by opening the door of the autoclave and allowing the packages to air dry. Handling a wet package can compromise its sterility.

NOTE Endo-Therapy Accessories and other items which are marked by the words "AUTOCLAVE" or "AUTOCLAVABLE", a green band or yellow-green marking are compatible with autoclaving.

	Temperature	Exposure Time
Prevacuum	132 to 134°C (270 to 274_F)	5 minutes

Table 6.3

Chapter 7 Cleaning, Disinfection and Sterilization Procedures

7.1 Required Reprocessing Equipment

Preparation of the Equipment

Prior to cleaning, disinfection or sterilization, prepare the equipment shown in Figure 7.1.

CAUTION

Use basins which are at least 40 cm by 40 cm (16" by 16") in size and deep enough to allow the endoscope to be completely immersed. Do not wrap the endoscope's Insertion Tube and Universal Cord into a coil with a diameter smaller than 40 cm. The endoscope can be damaged if coiled too tightly.

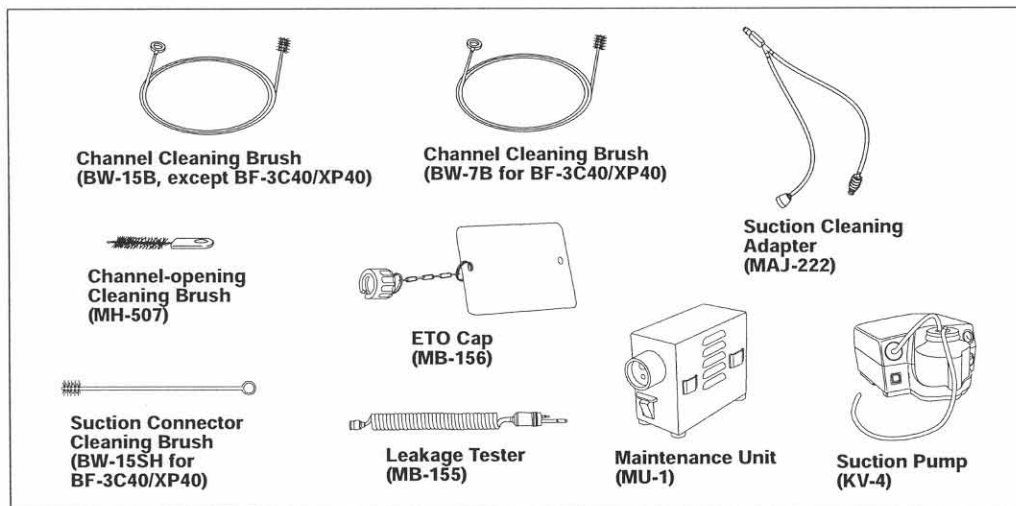

S Detergent Solution	S Large Non-metallic Basin with a Tight Fitting Lid for Detergent and Disinfectant Solution	S Soft Sponge
S Disinfectant Solution	S Large Basin for Rinsing	S Personal Protective Equipment
S Rinsing Water	S Large Basin for Leakage Testing	S Soft-Bristled Toothbrush
S 70% Ethyl or Isopropyl Alcohol	S 30 cm³ (30 ml) Syringe	S Lint-free Cloths

Figure 7.1

Reprocessing Equipment Parts and Functions

For inspection of other equipment than that mentioned below, refer to the instruction manual for the equipment being used.

WARNING Do not use the channel cleaning brush for cytologic tissue sampling or other diagnostic or therapeutic purposes. Patient injury, cross-contamination or equipment damage may occur.

ETO Cap (MB-156)

When performing ETO Gas Sterilization, the ETO Cap must be attached to the Venting Connector on the Endoscope Connector. (See Figure 7.2)

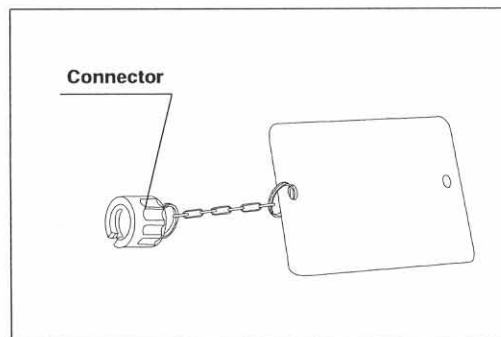

Figure 7.2

Suction Cleaning Adapter (MAJ-222)

When reprocessing, the Suction Cleaning Adapter is used to aspirate fluids from the Distal End of the endoscope through the channel. (See Figure 7.3)

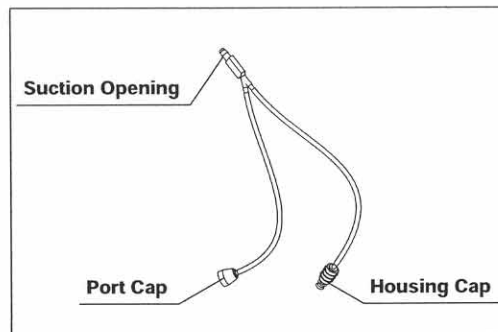

Figure 7.3

**Channel Cleaning Brush (BW-15B/7B)
Suction Connector Cleaning Brush (BW-15SH)**

The Channel Cleaning Brush is used to brush the inside of the channel. (See Figure 7.4)

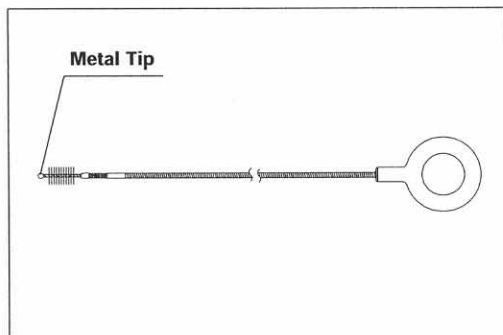

Figure 7.4

Channel-opening Cleaning Brush (MH-507)

The Channel-opening Cleaning Brush is used to brush, the Suction Valve Housing and the Instrument Channel Opening. (See Figure 7.5)

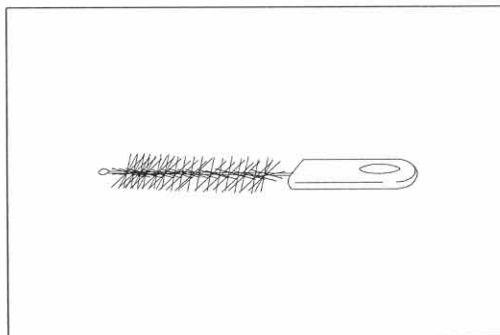

Figure 7.5

Inspection of the Equipment

For inspection of other equipment than that mentioned below, refer to the instruction manual for the equipment being used.

CAUTION The cleaning brushes are consumable items. Should the slightest irregularity be suspected, use a spare instead. Using a defective brush may cause equipment damage.

~ Inspection of the ETO Cap

Confirm that the ETO Cap is free from scratches, flaws and debris. (See Figure 7.2)

~ Inspection of the Suction Cleaning Adapter

Confirm that the adapter is free from cracks, scratches, flaws, debris and/or other damage. (See Figure 7.3)

~ Inspection of the Channel Cleaning Brushes and the Suction Connector Cleaning Brush

1. Confirm that the brush section and the metal tip of the distal end are securely in place. Check for loose or missing bristles.
2. Check for bends, scratches and other damage to the shaft.
3. Check for debris on the shaft and/or in the bristles of the brush.

~ Inspection of the Channel-opening Cleaning Brush

1. Check for loose or missing bristles.
2. Check for debris on the shaft and/or in the bristles of the brush.

7.2 Cleaning, Disinfection and Sterilization Procedures

Reprocessing Summary Chart

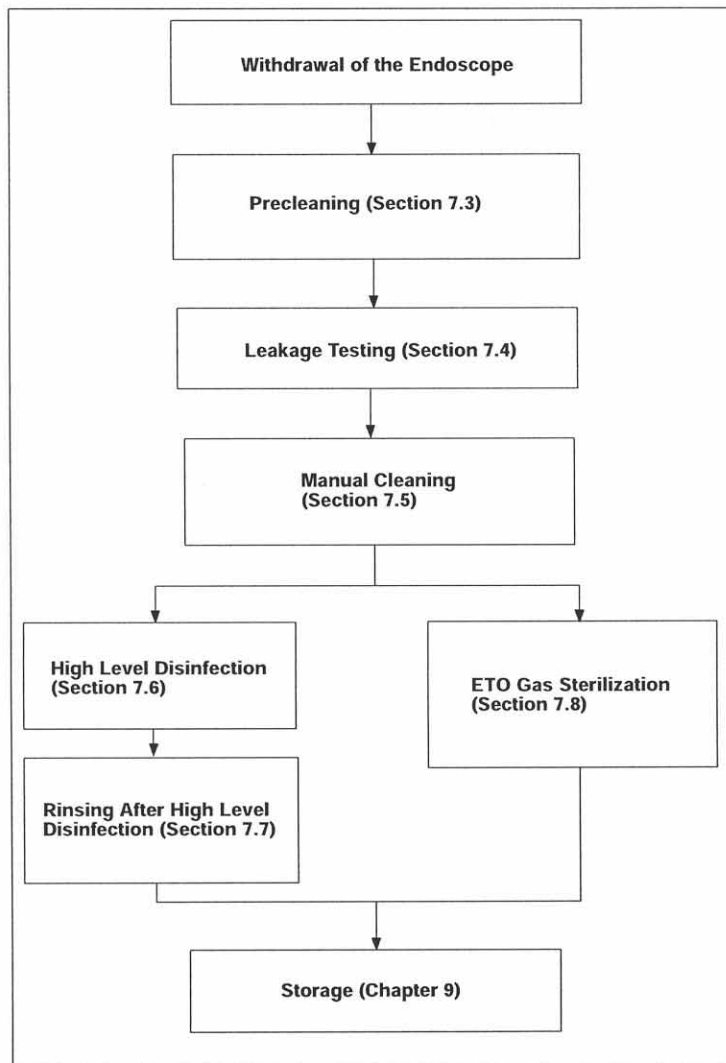

7.3 Precleaning

Preclean the endoscope at the bedside in the procedure room immediately following the procedure. These steps are to be performed when the Light Source and Suction Pump are turned ON and still connected to the endoscope.

Equipment Needed

Prepare the following equipment:

- § Personal Protective Equipment
- § Clean, Lint-free Cloths
- § Detergent Solution 500 cm³ (500 ml) Container

Wipe Down the Insertion Tube

CAUTION Handle the Insertion Tube carefully. Tightly gripping or sharply bending the Insertion Tube or Bending Section can stretch or severely damage the Insertion Tube and the covering of the Bending Section.

1. Prepare the detergent solution in a 500 cm³ (500 ml) container.
2. Wipe the entire Insertion Tube with a clean, lint-free cloth soaked in detergent solution. Wipe from the Boot toward the Distal End.

Aspirate Detergent Solution

CAUTION Monitor the bottle on the Suction Pump carefully to ensure that it does not overflow, as this could result in damage to the Suction Pump.

1. Turn the Suction Pump ON.
2. Immerse the Distal End of the Insertion Tube in the detergent solution. Depress the Suction Valve and aspirate detergent solution into the channel for 30 seconds.
3. Remove the Distal End of the Insertion Tube from detergent solution. Depress the Suction Valve and aspirate air for 10 seconds.
4. Turn the Suction Pump OFF.
5. Turn the Light Source OFF.

Disconnect the Endoscope, Reusable Parts and Cleaning Equipment

1. Disconnect the suction tube from the Suction Connector of the Suction Valve.
2. Remove the Suction Valve from the endoscope and discard it. (See Figure 7.6)

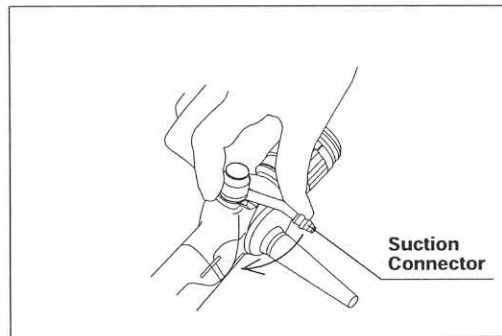

Figure 7.6

3. Remove the Biopsy Valve from the endoscope and discard it. (See Figure 7.7)

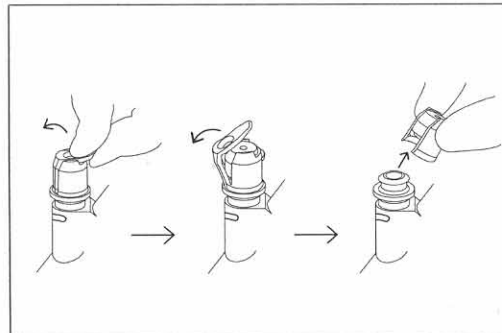

Figure 7.7

4. Disconnect the Endoscope Connector from the Light Source.

WARNING

The Endoscope Connector is very hot immediately after it is disconnected. Avoid touching it.

7.4 Leakage Testing

After precleaning, perform leakage testing on the endoscope to ensure that it is waterproof.

Equipment Needed

Prepare the following equipment:

- § Personal Protective Equipment
- § Large Basin
- § Maintenance Unit or Light Source (MU-1) or (CLV-U40)
- § Leakage Tester (MB-155)

CAUTION

- § Never connect or disconnect the Leakage Tester connector cap while immersed. Doing so could allow water to enter the endoscope and may damage the endoscope.
- § Rotate the Leakage Tester connector cap until it stops. If it is not fully and properly attached, the endoscope's interior will not be pressurized and accurate leakage testing will be impossible.
- § During leakage testing, a continuous series of bubbles emerging from a location on the endoscope indicates a leak at that location. This means that water will be able to penetrate the endoscope. If you locate a leak, remove the endoscope from the water and contact Olympus.
- § Always disconnect the Leakage Tester connector from the Light Source or Maintenance Unit before detaching the Leakage Tester's connector cap from the Venting Connector. Detaching the Leakage Tester's connector cap from the Venting Connector while the Leakage Tester is still connected to the Light Source will not allow the endoscope to depressurize properly and may damage the endoscope.
- § Always wipe the Leakage Tester thoroughly. Any water remaining on the Leakage Tester may cause damage to the endoscope.

NOTE

When the Leakage Tester connector is in place, the covering of the Bending Section will expand as the air pressure inside the endoscope increases. This is normal.

1. Fill a basin with water. Use a basin which is at least 40 cm by 40 cm (16" by 16") in size and deep enough to allow the endoscope to be completely immersed.

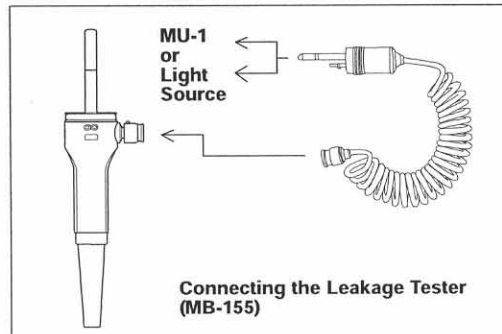

Figure 7.8

2. Insert the Leakage Tester connector into the output socket of the Maintenance Unit (MU-1) or the Light Source and turn the Maintenance Unit or the Light Source ON. Set the Light Source airflow switch to "HIGH" or "3". (See Figure 7.8)
3. Confirm that the Leakage Tester is emitting air by gently depressing the pin located inside the Leakage Tester's connector cap.
4. Attach the Leakage Tester to the Venting Connector on the Endoscope Connector. (See Figure 7.8)
5. With the Leakage Tester connected, immerse the endoscope in water and observe for approximately 30 seconds while angulating the Bending Section. Confirm that there is no location on the endoscope from which a continuous series of bubbles emerges.
6. Remove the endoscope from the basin.
7. Turn the Maintenance Unit or the Light Source OFF.
8. Disconnect the Leakage Tester from the Maintenance Unit or Light Source.
9. Wait 30 seconds or until the covering of the Bending Section contracts to its pre-expansion size. Disconnect the Leakage Tester's connector cap from the venting connector.
10. Thoroughly dry the Leakage Tester.

7.5 Manual Cleaning

After completing the leakage test, perform manual cleaning according to the procedures described below.

Equipment Needed

Prepare the following equipment:

- § Personal Protective Equipment
- § Sponge
- § Clean, Lint-free Cloths
- § Large Basins
- § Low-foaming Detergent Solution
- § Clean Water
- § Suction Cleaning Adapter (MAJ-222)
- § Channel Cleaning Brush (BW-15B, except BF-3C40/XP40)
- § Channel Cleaning Brush (BW-7B for BF-3C40/XP40)
- § Suction Connector Cleaning Brush (BW-15SH for BF-3C40/XP40)
- § Channel-opening Cleaning Brush (MH-507)

CAUTION To prevent damage to the endoscope, never immerse the endoscope together with objects such as Endo-Therapy accessories.

Cleaning the External Surface

1. Fill a basin with water and low-foaming detergent solution at a temperature and concentration recommended by the manufacturer. Use a basin which is at least 40 cm by 40 cm (16" by 16") in size and deep enough to allow the endoscope to be completely immersed.
2. Immerse the endoscope in the basin containing detergent solution.
3. With the endoscope immersed, use a soft brush or lint-free cloth to thoroughly brush and wipe all external surfaces of the endoscope.

Brushing the Channel

WARNING

- S To avoid splattering of detergent solution when the Channel Cleaning Brush is pulled out, keep the endoscope submerged.
- S The Channel Cleaning Brush is an item that is subject to wear. Repeated using may cause the brush head being bent or kinked, as a result the brush head may be come off. Confirm that the brush is free from any damages or other irregularities before and after each use. If the brush head comes off after brushing, immediately retrieve it and carefully check that it is not left inside the channel of the endoscope by passing a new cleaning brush or other endo-therapy accessories. If the brush head is left in the channel, it can drop into the patient body during the procedure. Depending on the staying location, the missing part may not be recoverable by passing a new brush or other endo-therapy accessories. In this case, contact Olympus.

CAUTION

The Channel Cleaning Brush (BW-7B) and Suction Connector Cleaning Brush (BW-15SH) have been designed for brushing the channel of the BF-3C40/XP40. Any other cleaning brush may cause equipment damage.

While the endoscope is submerged, brush the channel in the following order. (See Figure 7.9)

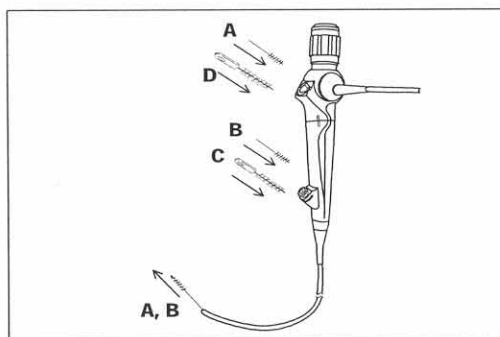

Figure 7.9

˘ **Brushing the Channel Through the Suction Valve Housing (Location A)**

1. Straighten the endoscope's Bending Section. Grip the Channel Cleaning Brush (BW-15B or BW-7B) 3 cm from the bristles.
2. Insert the Channel Cleaning Brush into the Suction Valve Housing as illustrated by A in Figure 7.9. Using short strokes, feed the brush through the channel until it emerges from the Distal End of the endoscope.
3. Clean off the bristles with your fingertips in detergent solution. Carefully pull the brush back through the channel.
4. Clean off the bristles in detergent solution again.
5. Repeat until all debris is removed.
6. For the BF-3C40/XP40, insert the Suction Connector Cleaning Brush (BW-15SH) into the Suction Valve Housing until it stops.
7. Pull the brush out and clean off the bristles in detergent solution.
8. Repeat until all debris is removed.

˘ **Brushing the Channel Through the Instrument Channel Port (Location B)**

1. Grip the Channel Cleaning Brush (BW-15B) or Suction Connector Cleaning Brush (BW-15SH for BF-3C40/XP40) 3 cm from the bristles.
2. Insert the Channel Cleaning Brush into the Instrument Channel Port as illustrated by B in Figure 7.9. Using short strokes, feed the brush through the Channel until it emerges from the Distal End of the endoscope.
3. Clean off the bristles with your fingertips in detergent solution. Carefully pull the brush back through the channel.
4. Clean off the bristles in detergent solution again.
5. Repeat until all debris is removed.

˘ **Brushing the Instrument Channel Port (Location C)**

1. Insert the Channel-opening Cleaning Brush (MH-507) into the Instrument Channel Port until the brush handle hits the channel opening as illustrated by C in Figure 7.9. Turn the brush once.
2. Pull the brush out and clean off the bristles in detergent solution.

3. Repeat until all debris is removed.

Brushing the Suction Valve Housing (Location D)

CAUTION

When inserting the Channel-opening Cleaning Brush into the Suction Valve Housing, do not forcibly insert the brush beyond the middle of the bristles section. Otherwise, the brush may become stuck in the Suction Valve Housing.

1. Insert the Channel-opening Cleaning Brush into the Suction Valve Housing as illustrated by D in Figure 7.9 until half of the bristles section is inserted. Turn the brush once.
2. Pull the brush out and clean off the bristles in detergent solution.
3. Repeat until all debris is removed.
4. Soak the cleaning brushes (MH-507 and BW-15B) in detergent solution, then reprocess them as described in Section 7.9, "Cleaning, Disinfection and Sterilization Procedures for Reusable Parts and Cleaning Equipment".

Aspirating Detergent Solution Into the Channel

1. Attach the Suction Cleaning Adapter's Port Cap to the Instrument Channel Port. Attach the Housing Cap to the Suction Valve Housing.
2. Attach the suction tube to the Suction Opening of the Suction Cleaning Adapter. Turn the Suction Pump ON.
3. Aspirate detergent solution for approximately 30 seconds while immersing the endoscope in detergent solution.
4. Turn the Suction Pump OFF.

Flushing Detergent Solution Into the Channel

1. Disconnect the suction tube from the Suction Cleaning Adapter. Completely immerse the endoscope and Suction Cleaning Adapter.
2. Attach the 30 cm³ (30ml) syringe to the suction opening on the adapter.
3. Withdraw the plunger of the syringe to fill the Suction Cleaning Adapter and the Channel with detergent solution. (See Figure 7.10)
4. With the endoscope and Suction Cleaning Adapter completely immersed in detergent solution, disconnect the Suction Cleaning Adapter.

CAUTION

Do not pull the tubes of Suction Cleaning Adapter when disconnecting the Suction Cleaning Adapter from the endoscope.

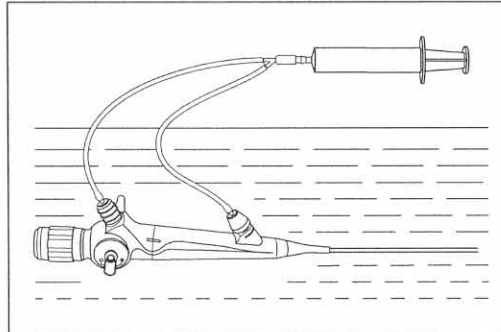

Figure 7.10

Soaking all Components in Detergent Solution

1. Using a soft sponge or lint-free cloth, wipe all debris from the endoscope's outer surface while the endoscope remains immersed in detergent solution.
2. Cover the basin with a tight fitting lid.
3. Soak the endoscope and Suction Cleaning Adapter for the amount of time and at the temperature recommended by the detergent manufacturer.

Remove and Rinse the Endoscope and Equipment

1. Remove the endoscope and Suction Cleaning Adapter from detergent solution and place them in clean water.
2. Attach the Suction Cleaning Adapter to the endoscope and to the suction pump tube.
3. Turn the Suction Pump ON. Aspirate clean water for 30 seconds.
4. Remove the endoscope, together with the Suction Cleaning Adapter, from water and aspirate air for 20 seconds.
5. Turn the Suction Pump OFF. Disconnect the Suction Cleaning Adapter from the endoscope.
6. Use a clean, lint-free cloth to thoroughly dry the external surfaces of the endoscope and Suction Cleaning Adapter.

Presoak for Excessive Bleeding and/or Delayed Reprocessing

CAUTION Follow the steps below only in case of excessive bleeding and/or delayed reprocessing; unnecessary immersion must be avoided. Consecutive extended immersions may damage the endoscope.

Preclean the endoscope by following the procedures outlined in Section 7.3, "Precleaning" and Section 7.4, "Leakage Testing".

1. Fill a basin with detergent solution at a temperature and concentration recommended by the manufacturer. Use a basin which is at least 40 cm by 40 cm (16" by 16") in size and deep enough to completely immerse the endoscope.
2. Carefully coil the endoscope's insertion tube and universal cord and completely immerse the endoscope in detergent solution.

CAUTION Do not coil the Insertion Tube and Universal Cord with a diameter of less than 10 cm. Equipment damage can result.

3. Connect the Suction Cleaning Adapter to the endoscope. Completely immerse the endoscope in detergent solution.
4. Attach a 30 cm³ (30 ml) syringe to the Suction Cleaning Adapter. Withdraw the plunger of the syringe to fill the Channel and Suction Cleaning Adapter with detergent solution.
5. With the endoscope and Suction Cleaning Adapter completely immersed in detergent solution, disconnect the Suction Cleaning Adapter.

CAUTION Disconnect the Suction Cleaning Adapter from the endoscope only while it is completely immersed. Disconnecting when not immersed may allow air to be drawn into the channel and will reduce the effectiveness of the detergent soak.

6. Soak the endoscope for 1 hour at the temperature recommended by the detergent manufacturer.
7. Remove the endoscope from detergent solution.

After soaking the endoscope, manually clean the endoscope following the standard procedure described in Section 7.5, "Manual Cleaning", then disinfect or sterilize the endoscope following the procedures described in Section 7.6, "High Level Disinfection" or Section 7.8, "Sterilization".

7.6 **High Level Disinfection**

After manual cleaning, disinfect the endoscope according to the procedure described below.

Equipment Needed

Prepare the following equipment:

- § Personal Protective Equipment
- § Clean, Lint-free Cloths
- § Large Basin
- § Sponge
- § Disinfectant Solution
- § Suction Cleaning Adapter (MAJ-222)

CAUTION All disinfection steps should be performed with the endoscope and all equipment completely immersed. Otherwise, disinfectant solution may not adequately contact all surfaces of the equipment. As a result, the effectiveness of disinfection may be reduced.

Preparations

Fill a basin with disinfectant solution at the temperature and concentration specified on the manufacturer's label. Use a basin which is at least 40 cm by 40 cm (16" by 16") in size and deep enough to allow the endoscope to be completely immersed.

Flushing Disinfectant Solution Into the Channel

CAUTION

All disinfection steps should be performed with all equipment completely immersed. If the equipment is connected or disconnected while not immersed, disinfectant solution may not adequately contact all surfaces of the equipment, and the effectiveness of disinfection may be reduced.

1. Connect the Suction Cleaning Adapter to the endoscope.
2. Attach the 30 cm³ (30 ml) syringe to the Suction Cleaning Adapter.
3. Immerse the endoscope in disinfectant solution. Pull the plunger of the syringe to fill the channel and Suction Cleaning Adapter with disinfectant solution.
4. With the endoscope and the Suction Cleaning Adapter completely immersed in disinfectant solution, disconnect the Suction Cleaning Adapter from the endoscope.
5. Should air bubbles adhere to the surfaces of the endoscope and Suction Cleaning Adapter, remove them using a clean, lint-free cloth.
6. Cover the basin with a tight fitting lid.

Soaking the Endoscope and Cleaning Equipment

Soak the endoscope and cleaning equipment for the amount of time and at the temperature recommended by the disinfectant manufacturer. It is recommended to use a timer to monitor soaking time.

Removing the Endoscope and Cleaning Equipment From the Disinfectant Solution

1. Remove the endoscope and Suction Cleaning Adapter from disinfectant solution, attach the Suction Cleaning Adapter to the endoscope.
2. Use a 30 cm³ (30 ml) syringe to inject air until no disinfectant solution exits the Distal End.
3. Disconnect the Suction Cleaning Adapter and the syringe from the endoscope.

7.7 Rinsing After High Level Disinfection

Use water of appropriate microbiological quality. Once removed from the disinfectant, the instrument must be thoroughly rinsed with sterile water to remove any disinfectant residue. If sterile water is not available, fresh potable tap water or water which has been processed (e.g. filtered) to improve its microbiological quality may be used along with a 70% ethyl or isopropyl alcohol rinse (See "If Non-sterile Water is Used" on page 60). Consult with your hospital's infection control committee.

Two rinse procedures are described below.

If Sterile Water is Used

1. Immerse the endoscope and Suction Cleaning Adapter in sterile water. Using a clean, lint-free cloth or sponge, thoroughly rinse and wipe all outer surfaces.
2. Connect the Suction Cleaning Adapter and Suction Pump to the endoscope. Turn the Suction Pump ON.
3. Aspirate sterile water for 30 seconds.
4. Remove the endoscope from sterile water and aspirate air for 60 seconds.
5. Turn the Suction Pump OFF. While holding the Control Section and directing the Instrument Channel Port downward, disconnect the Suction Cleaning Adapter from the endoscope. (See Figure 7.11)
6. Wipe and dry the endoscope and Suction Cleaning Adapter with a sterile, lint-free cloth.

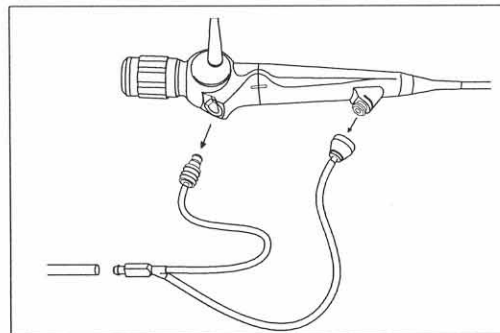

Figure 7.11

If Non-sterile Water is Used

CAUTION Alcohol is flammable. Handle with care.

1. Immerse the endoscope and Suction Cleaning Adapter in non-sterile water. Using a clean, lint-free cloth or sponge, thoroughly rinse and wipe all outer surfaces.
2. Connect the Suction Cleaning Adapter and Suction Pump to the endoscope. Turn the Suction Pump ON.
3. Aspirate non-sterile water for 30 seconds.
4. Remove the endoscope, aspirate air for 60 seconds.
5. Immerse the Distal End of the endoscope in the container containing alcohol. Aspirate alcohol for 5 seconds.
6. Remove the Distal End from the container, and aspirate air for 20 seconds.
7. Turn the Suction Pump OFF. While holding the Control Section and directing the Instrument Channel Port downward, disconnect the Suction Cleaning Adapter from the endoscope. (See Figure 7.11)
8. Wipe and dry the endoscope and Suction Cleaning Adapter with a sterile, lint-free cloth.

7.8 Sterilization

ETO Gas Sterilization

As an alternative to high-level disinfection, the endoscope can be sterilized by ethylene oxide gas. After performing manual cleaning and drying as described in Section 7.3, "Precogning" and Section 7.5, "Manual Cleaning", follow the directions given below.

1. Seal the instrument in a package appropriate for ethylene oxide gas sterilization according to your hospital's protocol.
2. Sterilize the instrument according to the Recommended ETO Gas Exposure Parameters described in Section 6.5, "ETO Gas Sterilization" and the sterilizer manufacturer's instructions.
3. Aerate the components following the Minimum Aeration Parameters specified in Section 6.5, "ETO Gas Sterilization".
4. Store the components following the instructions given in Chapter 9, "Storage".

7.9 **Cleaning, Disinfection and Sterilization Procedures for Reusable Parts and Cleaning Equipment**

This section includes the cleaning, disinfection and sterilization procedures for reusable parts and cleaning equipment. For all other parts, refer to their respective instruction manuals. Attach the ETO Cap (MB-156) to the endoscope and clean, disinfect and sterilize it together with the endoscope according to Section 7.8, "Sterilization". Clean, disinfect and sterilize the Suction Cleaning Adapter (MAJ-222) together with the endoscope.

§ Mouthpiece	(MA-651)
§ Channel Cleaning Brush	(BW-15B)
§ Channel Cleaning Brush	(BW-7B for BF-3C40/XP40)
§ Suction Connector Cleaning Brush	(BW-15SH for BF-3C40/XP40)
§ Channel-opening Cleaning Brush	(MH-507)

Manual Cleaning

1. Immerse all the parts and equipment in a basin of detergent solution prepared according to the manufacturer's instructions.

CAUTION Make sure that the items immersed in detergent solution do not contact one another.

2. Using a clean, soft brush, sponge or lint-free cloth, meticulously clean the outer surfaces in detergent solution. Clean the bristles of the cleaning brushes (BW-15B/7B/15SH and MH-507) thoroughly while the brushes are immersed.
3. Soak them for the amount of time and at the temperature recommended by detergent manufacturer.
4. Remove them from detergent solution and place them in clean water.
5. Visually inspect them. If debris remains, ultrasonically clean at 38 to 47 kHz for 5 minutes.
6. Remove them from clean water.
7. Wipe and dry their external surfaces equipment with a clean, lint-free cloth.

High Level Disinfection

1. Adjust the concentration and temperature of disinfectant solution according to the manufacturer's instructions.
2. Immerse all the parts and equipment in a basin containing disinfectant solution.
3. Rub the bristles of the cleaning brushes to ensure that all air bubbles are removed.
4. Using a clean, lint-free cloth, wipe away any air bubbles adhering to surfaces.
5. Soak them for the amount of time and at the temperature recommended by the disinfectant manufacturer.

Rinsing After High Level Disinfection

Once removed from disinfectant solution, the instrument must be thoroughly rinsed with sterile water to remove any disinfectant residue. If sterile water is not available, fresh potable tap water or water which has been processed (e.g. filtered) to improve its microbiological quality may be used in conjunction with an alcohol flush. Consult with your hospital's infection control committee.

If non-sterile water is used for rinsing, all the parts and equipment must be wiped and flushed with 70% ethyl or isopropyl alcohol.

If Sterile Water is Used

1. Remove the remaining parts and equipment from disinfectant solution and immerse them in a basin of sterile water.
2. Gently agitate them to thoroughly rinse.
3. Remove them from sterile water.
4. Wipe and dry their external surfaces with a sterile, lint-free cloth.

If Non-sterile Water is Used

1. Fill a small container with 70% ethyl or isopropyl alcohol.
2. Remove the remaining parts and equipment from the disinfectant solution and immerse them in a basin of non-sterile water.
3. Gently agitate them to thoroughly rinse.
4. Remove them from non-sterile water.
5. Immerse them in the alcohol. While immersed, agitate the parts.
6. Remove them from the alcohol.
7. Wipe and dry their external surfaces with a sterile, lint-free cloth.

Sterilization

ETO Gas Sterilization

CAUTION The Channel Cleaning Brush and Channel-opening Cleaning Brush are not compatible with ETO gas sterilization.

After cleaning and drying as described in "Manual Cleaning" on page 62, follow the directions given below.

1. Before sterilization, the parts and equipment must be thoroughly cleaned and dried.
2. Seal the individual parts or equipment in packages appropriate for ethylene oxide gas sterilization according to your hospital's protocol.
3. Sterilize the instrument according to the recommended ETO Gas Exposure Parameters described in Section 6.5, "ETO Gas Sterilization" and the sterilizer manufacturer's instructions.
4. Aerate the components following the Minimum Aeration Parameters specified in Section 6.5, "ETO Gas Sterilization".
5. Store the components following the instructions given in Chapter 9, "Storage".

Steam Sterilization (Autoclaving)

After cleaning as described in "Manual Cleaning" on page 62, steam sterilize according to the instructions given below.

1. Before sterilization, the parts and equipment must be thoroughly cleaned and dried. Residual moisture inhibits sterilization.
2. Seal the individual parts or equipment in packages appropriate for steam sterilization (autoclaving) according to your hospital's protocol.
3. Steam sterilize the instrument according to the parameters described in Section 6.6, "Steam Sterilization (Autoclaving) of Accessories", and the sterilizer manufacturer's instructions.
4. Following steam sterilization (autoclaving), let all components gradually cool down to room temperature. Sudden changes in temperature may damage the instruments.

Chapter 8 Washing and Disinfection Equipment

8.1 Washing and Disinfection Equipment

The endoscope is compatible with some endoscope washers recommended by Olympus. Refer to the respective instructions manual for details on operation.

Chapter 9 Storage

9.1 Storage

CAUTION

- S The storage cabinet must be clean, dry, well ventilated and maintained at ambient temperature. Storing the endoscope in direct sunlight, at high temperatures, in high humidity or exposed to X-rays may damage the endoscope or present an infection control risk.
 - S Prior to storage, detach all removable parts from the endoscope. Removing the Suction Valve and Biopsy Valve will allow air to circulate through the channel of the endoscope and will assist drying.
 - S Do not store the endoscope in the carrying case. Use the carrying case only for shipping the endoscope. Routinely storing the endoscope in a humid, non-ventilated environment such as the carrying case may present an infection control risk.
1. Before storage of a high-level disinfected endoscope, thoroughly dry all parts of the endoscope (outer surfaces, channel) and all accessories (e.g. biopsy forceps).
 2. Hang the endoscope in the storage cabinet with the Distal End hanging freely. Make sure that the Insertion Tube hangs vertically and as straight as possible.

Chapter 10 Troubleshooting

If the endoscope is visibly damaged, does not function as expected or is found to have other irregularities during the inspection described in Chapter 3, "Preparation and Inspection", do not use the endoscope. Contact Olympus.

Some problems that appear to be malfunctions may be correctable by referring to Section 10.1, "Troubleshooting Guide". If the problem cannot be resolved by the described remedial action, stop using the endoscope and send it to Olympus for repair.

Olympus does not repair accessory parts. If an accessory part becomes damaged, contact Olympus to purchase a replacement.

WARNING Never use the endoscope on a patient if an abnormality is suspected.

10.1 Troubleshooting Guide

Image Quality or Brightness

Irregularity Description	Possible Cause	Solution
Image is not clear.	Dirty objective lens.	Clean objective lens with a cotton swab moistened with 70% ethyl or isopropyl alcohol.
	Dirty eyepiece lens.	Clean eyepiece lens with a cotton swab moistened with 70% ethyl or isopropyl alcohol.
	Optics not adjusted properly.	Rotate the Diopter Adjustment Ring until fiber pattern is clear.
Excessively dark or bright images.	Improper Light Source setting.	Refer to the Light Source's instruction manuals.

Suction

Irregularity Description	Possible Cause	Solution
Absent or insufficient suction.	Improper Suction Pump setting.	Refer to the Suction Pump's instruction manual.
	Suction Valve is damaged.	Replace it with a new Suction Valve.
	Biopsy Valve is damaged.	Replace it with new Biopsy Valve.
	Biopsy Valve is improperly installed.	Install Biopsy Valve correctly.
Sticky Suction Valve.	Valve is damaged.	Replace it with a new Suction Valve.
Suction Valve does not return to its original position.	Too much pressure.	Lower aspiration pressure.

Water Feeding

Irregularity Description	Possible Cause	Solution
Fluid leaking from Biopsy Valve.	Valve is improperly installed.	Install Biopsy Valve correctly.
	Syringe is not inserted securely.	Insert correctly.

Endo-Therapy Accessories

Irregularity Description	Possible Cause	Solution
Endo-Therapy Accessory does not pass through the instrument channel smoothly.	An incompatible Endo-Therapy Accessory is being used.	Refer to the "System Chart" in the Appendix and select a compatible Endo-Therapy Accessory. Confirm that the color coding on the Endo-therapy Accessory match that on the endoscope.

10.2 Returning the Endoscope for Repair

WARNING

Thoroughly clean and high-level disinfect or sterilize the endoscope before returning it for repair. Improperly reprocessed equipment presents an infection control risk to each person who handles the endoscope within the hospital or at Olympus.

CAUTION

Olympus is not liable for any injury or damage which occurs as a result of repairs attempted by non-Olympus personnel.

When returning the endoscope for repair, include a description of the endoscope malfunction or damage and the name and telephone number of the individual at your location who is most familiar with the endoscope problem. Also include a repair purchase order.

When returning the endoscope for repair, follow the instructions for "Transporting Outside the Hospital" in Section 4.4, "Transportation of the Endoscope".

Appendix

System Chart

The recommended combinations of equipment and accessories that can be used with this instrument are listed below. New products released after the introduction of this instrument may also be compatible for use in combination with this instrument. For further details, contact Olympus.

WARNING

If combinations of equipment other than those shown below are used, the full responsibility is assumed by the medical treatment facility.



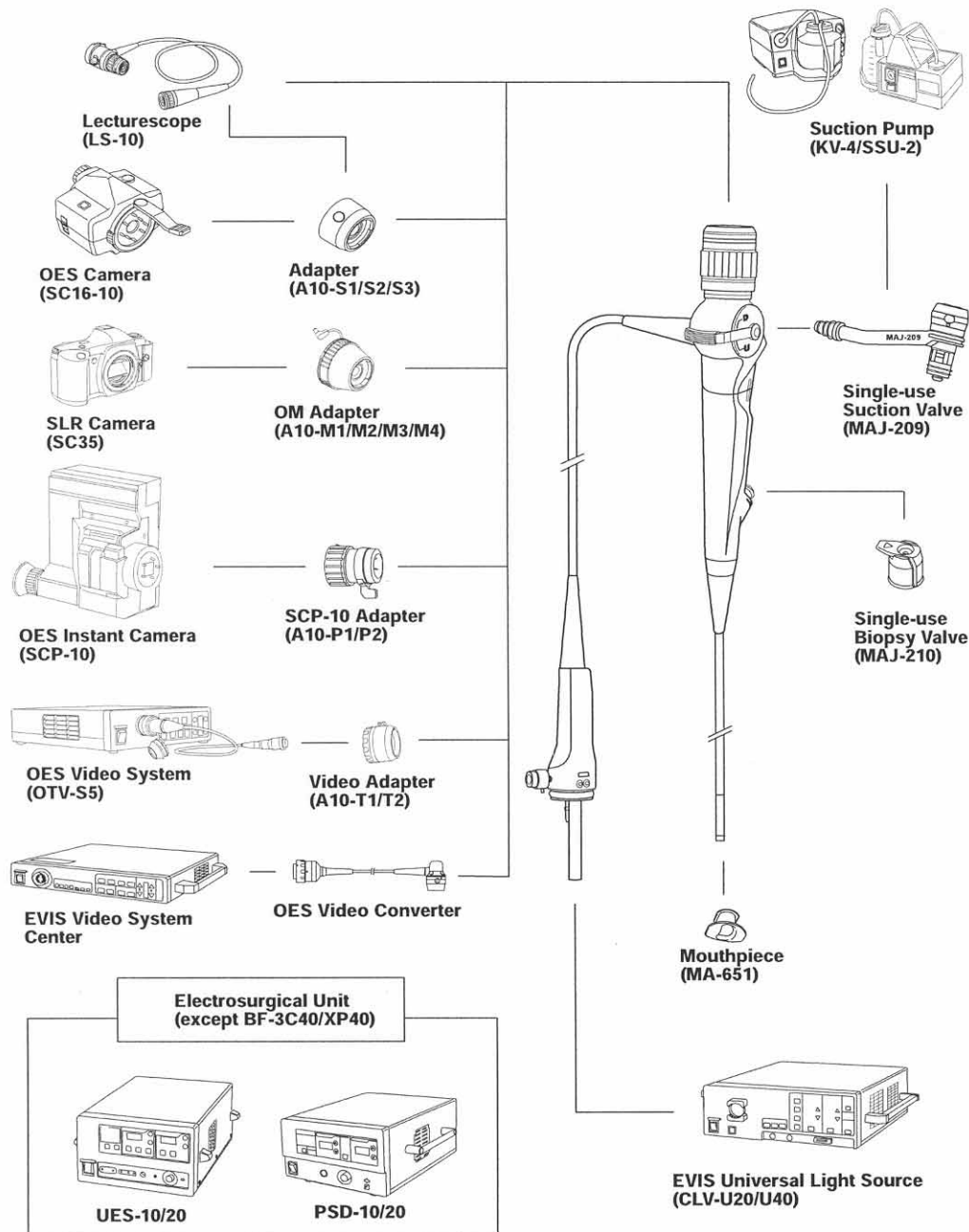

Endoscopic Equipment Combinations

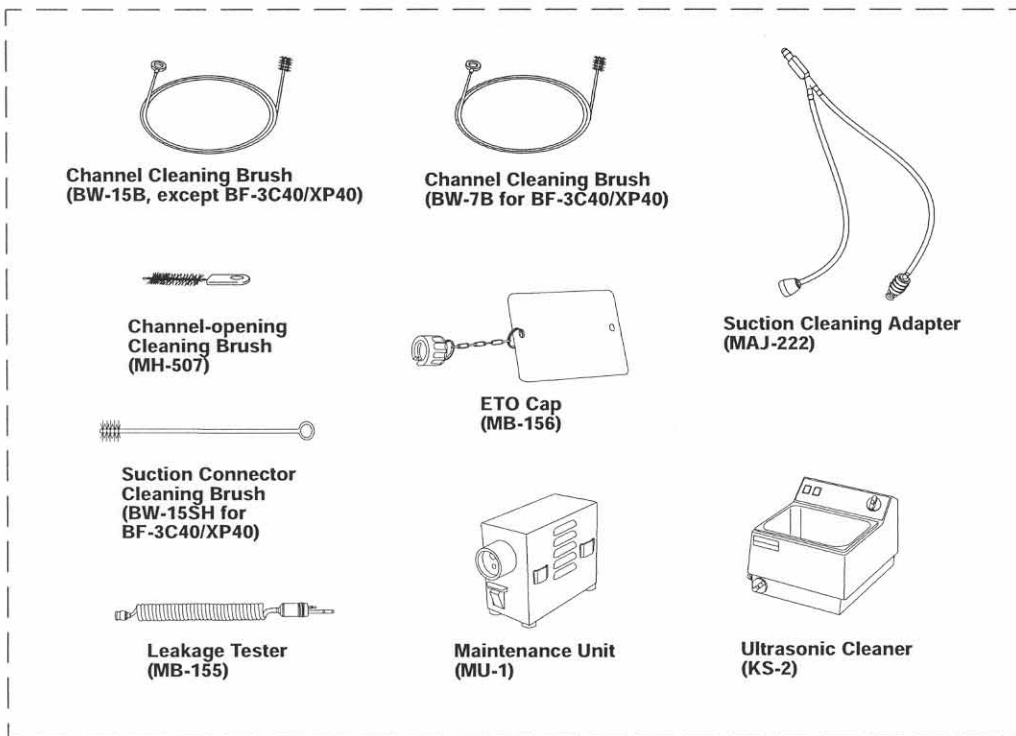









Cleaning and Disinfection Equipment





Endo-Therapy Accessories



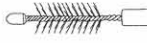

ENDO-THERAPY ACCESSORY	BIOPSY FORCEPS			
	Alligator jaws	Swing type	Fenestrated	Fenestrated with needle
FIBERSCOPE				
BF-1T40	FB-15C-1	FB-52C-1	FB-20C-1	FB-34C-1
BF-40/P40	FB-15C-1	FB-52C-1	FB-19C-1	FB-34C-1
BF-XT40	FB-36C-1	FB-52C-1	FB-35C-1	FB-34C-1
BF-3C40/XP40	-	-	-	-





ENDO-THERAPY ACCESSORY	BIOPSY FORCEPS			
	Ellipsoid	Ellipsoid with needle	Rat tooth	Alligator type
FIBERSCOPE				
BF-1T40	FB-21C-1	FB-22C-1	-	-
BF-40/P40	FB-21C-1	-	-	-
BF-XT40	FB-21C-1	FB-24K-1	FB-37K-1	FB-11K-1
BF-3C40/XP40	FB-44D-1/FB-56D-1	-	-	-

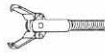



ENDO-THERAPY ACCESSORY	ROTATABLE BIOPSY FORCEPS		CYTOLOGY BRUSH	
	Fenestrated	Ellipsoid with needle	Double-joint	With sheath
FIBERSCOPE				
BF-1T40	FB-19CR-1	FB-22CR-1	BC-8C I	BC-9C I
BF-40/P40	FB-19CR-1	-	BC-8C I	BC-5C I
BF-XT40	FB-19CR-1	FB-22CR-1	BC-8C I	BC-9C I
BF-3C40/XP40	-	-	-	-





ENDO-THERAPY ACCESSORY	CYTOLOGY BRUSH		CYTOLOGY CURETTE	
	Standard type	Disposable		
FIBERSCOPE				
BF-1T40	BC-10C I	BC-202D -1210 5010	CC-4CR-1 I	CC-5CR-1 I
BF-40/P40	BC-10C I	BC-202D -1210 5010	CC-4CR-1 I	CC-5CR-1 I
BF-XT40	BC-10C I	BC-202D -1210 5010	CC-4CR-1 I	CC-5CR-1 I
BF-3C40/XP40	-	BC-201C-1006	-	-



I : These accessories may not be available in some areas.

ENDO-THERAPY ACCESSORY	GRASPING FORCEPS			
	Rubber Tips	W-shape	Rat tooth	Sharp tooth
FIBERSCOPE				
BF-1T40	FG-20P-1	FG-25C-1	FG-26C-1	-
BF-40/P40	FG-20P-1	-	-	-
BF-XT40	FG-20P-1	FG-25C-1	FG-26C-1	FG-32C-1
BF-3C40/XP40	-	-	-	-

ENDO-THERAPY ACCESSORY	GRASPING FORCEPS			
	Alligator jaws	Basket type	Loop type	Spiral basket type
FIBERSCOPE				
BF-1T40	-	-	FG-36D	FG-51D
BF-40/P40	-	-	FG-36D	FG-51D
BF-XT40	FG-6L-1	FG-16L-1	FG-36D	FG-51D
BF-3C40/XP40	-	-	FG-36D	FG-51D



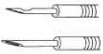

ENDO-THERAPY ACCESSORY	GRASPING FORCEPS			BALLOON CATHETER
	Spiral basket type	Three nail type	Parallel basket type	
FIBERSCOPE				
BF-1T40	FG-52D	FG-54D	FG-55D	B5-2C
BF-40/P40	FG-52D	FG-54D	FG-55D	B5-2C
BF-XT40	FG-52D	FG-54D	FG-55D	B7-2C
BF-3C40/XP40	FG-52D	FG-54D	FG-55D	-

ENDO-THERAPY ACCESSORY	MAGNETIC EXTRACTOR	CANNULA	SPRAY CATHETER	INJECTOR
		Standard type	Spray type	
FIBERSCOPE				
BF-1T40	IE-2P I	PR-2B-1	PW-6C-1	NM-1D I /8L/9L
BF-40/P40	IE-2P I	PR-2B-1	PW-6C-1	NM-3K I /8L/9L
BF-XT40	IE-1L I /2P I	PR-2B-1	PW-6C-1	NM-1D I , 4 9L
BF-3C40/XP40	-	-	-	-

ENDO-THERAPY ACCESSORY	ASPIRATION NEEDLE	MEASURING DEVICE	
		Standard	Bendable
FIBERSCOPE			
BF-1T40	NA-1C-1/2C-1	M1-1C I	M2-1C/2C I
BF-40/P40	NA-1C-1/2C-1	M1-1C I	M2-1C/2C I
BF-XT40	NA-1C-1/2C-1	M1-1C I	M2-1C/2C I
BF-3C40/XP40	-	-	-

I : These accessories may not be available in some areas.

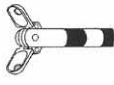
Electrosurgical Accessories

ENDO-THERAPY ACCESSORY	ELECTROSURGICAL SNARE	COAGULATION ELECTRODE	HOT BIOPSY FORCEPS	ELECTROSURGICAL KNIFE
		Ball point		Flat
FIBERSCOPE				
BF-1T40	SD-7C-1/18C-1	CD-6C-1	FD-6C-1/7C-1	KD-31C-1
BF-40/P40	SD-7C-1/18C-1	CD-6C-1	FD-7C-1	KD-31C-1
BF-XT40	SD-7C-1/18C-1	CD-6C-1	FD-6C-1/7C-1	KD-31C-1

OLYMPUS

OLYMPUS OPTICAL CO.,LTD.

2951 Ishikawa-cho, Hachioji-shi, Tokyo 192-8507, Japan
Fax: (0426)46-2429 Telephone: (0426)42-2111

OLYMPUS OPTICAL CO.(EUROPA) GMBH

(Premises/Goods delivery) Wendenstrasse 14-18, D-20097 Hamburg, Germany
(Letters) Postfach 10 49 08, D-20034 Hamburg, Germany Telephone: (040)237730

OLYMPUS AMERICA INC.

Two Corporate Center Drive, Melville, N.Y.
11747-3157, U.S.A.
Fax: (631)844-5442 Telephone: (631)844-5000

KEYMED LTD

KeyMed House, Stock Road, Southend-on-Sea, Essex SS2 5QH, United Kingdom
Telex: 995283 Fax: (01702)465677 Telephone: (01702)616333

OLYMPUS SINGAPORE PTE LTD

491B, River Valley Road #12-01/04, Valley Point Office Tower, Singapore 248373
Fax: 834-2438 Telephone: 834-0010

OLYMPUS BEIJING REPRESENTATIVE OFFICE

Rm. 818, South Tower, Beijing Kerry Centre, No.1 Guanghai Road, Chaoyang District, Beijing, 100020, China
Fax: (10)8529-8085 Telephone: (10)8529-8080

OLYMPUS MOSCOW LIMITED LIABILITY COMPANY

117071, Moscow, Malaya Kaluzhskaya 19, bld. 1, fl.2, Russia
Fax: (095)958-2277 Telephone: (095)958-2245

OLYMPUS AUSTRALIA PTY. LTD.

1/104 Ferntree Gully Road, Oakleigh, VIC 3166, Australia
Fax: (03)9543-1350 Telephone: (03)9265-5400

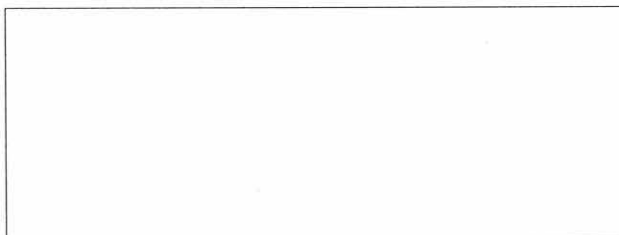

Style 10